

# CCS

## SECTION

# CRUISE CONTROL SYSTEM

A  
B  
C  
D  
E  
F  
G  
H  
I  
J  
K  
L  
M  
N  
P

## CONTENTS

<b>ICC</b>	
<b>PRECAUTION</b> .....	<b>4</b>
<b>PRECAUTIONS</b> .....	<b>4</b>
Precaution for Supplemental Restraint System (SRS) "AIR BAG" and "SEAT BELT PRE-TENSIONER" .....	4
Precautions For Harness Repair .....	4
ICC System Service .....	5
<b>PREPARATION</b> .....	<b>6</b>
<b>PREPARATION</b> .....	<b>6</b>
Special Service Tools .....	6
<b>SYSTEM DESCRIPTION</b> .....	<b>7</b>
<b>COMPONENT PARTS</b> .....	<b>7</b>
Component Parts Location .....	7
ICC Sensor .....	8
ADAS Control Unit .....	9
Brake Pedal Position Switch/Stop Lamp Switch .....	9
ICC Steering Switch .....	9
ICC Brake Hold Relay .....	10
Combination Meter .....	10
<b>SYSTEM</b> .....	<b>11</b>
System Description .....	11
Fail-safe (ADAS Control Unit) .....	14
Fail-safe (ICC Sensor) .....	14
<b>INTELLIGENT CRUISE CONTROL</b> .....	<b>14</b>
INTELLIGENT CRUISE CONTROL : System Description .....	15
<b>OPERATION</b> .....	<b>18</b>
<b>INTELLIGENT CRUISE CONTROL</b> .....	<b>18</b>
INTELLIGENT CRUISE CONTROL : Switch Name and Function .....	18
INTELLIGENT CRUISE CONTROL : Menu Displayed by Pressing Each Switch .....	18
<b>HANDLING PRECAUTION</b> .....	<b>22</b>
Precautions for Intelligent Cruise Control .....	22
<b>DIAGNOSIS SYSTEM (ADAS CONTROL UNIT)</b> .....	<b>25</b>
CONSULT Function (ICC/ADAS) .....	25
<b>DIAGNOSIS SYSTEM (ICC SENSOR)</b> .....	<b>31</b>
CONSULT Function (LASER/RADAR) .....	31
<b>ECU DIAGNOSIS INFORMATION</b> .....	<b>35</b>
<b>ADAS CONTROL UNIT</b> .....	<b>35</b>
Reference Value .....	35
Fail-safe (ADAS Control Unit) .....	39
DTC Inspection Priority Chart .....	39
DTC Index .....	40
<b>ICC SENSOR</b> .....	<b>42</b>
Reference Value .....	42
Fail-safe .....	45
DTC Inspection Priority Chart .....	45
DTC Index .....	46
<b>WIRING DIAGRAM</b> .....	<b>49</b>
<b>INTELLIGENT CRUISE CONTROL</b> .....	<b>49</b>
Wiring Diagram .....	49
<b>BASIC INSPECTION</b> .....	<b>54</b>
<b>DIAGNOSIS AND REPAIR WORK FLOW</b> .....	<b>54</b>
Work Flow .....	54
<b>ADDITIONAL SERVICE WHEN REPLACING ICC SENSOR</b> .....	<b>56</b>
Description .....	56
Work Procedure .....	56
<b>ICC SENSOR INITIAL VERTICAL ALIGNMENT</b> .....	<b>57</b>
Description .....	57
Required Tools .....	57



Preparation .....	57	<b>C1A16 RADAR BLOCKED OR STAINED</b> .....	89
ICC Sensor Initial Vertical Alignment .....	58	DTC Description .....	89
<b>ICC SENSOR ALIGNMENT</b> .....	<b>59</b>	Diagnosis Procedure .....	89
Description .....	59	<b>C1A17 ICC SENSOR</b> .....	<b>91</b>
Required Tools .....	59	DTC Description .....	91
Preparation .....	60	Diagnosis Procedure .....	91
Vehicle Set Up .....	61	<b>C1A18 RADAR AIMING INCOMP</b> .....	<b>92</b>
Setting The ICC Target Board .....	63	DTC Description .....	92
ICC Sensor Adjustment .....	64	Diagnosis Procedure .....	92
<b>ACTION TEST</b> .....	<b>66</b>	<b>C1A21 UNIT HIGH TEMP</b> .....	<b>93</b>
Description .....	66	DTC Description .....	93
Work Procedure .....	66	Diagnosis Procedure .....	93
<b>DTC/CIRCUIT DIAGNOSIS</b> .....	<b>70</b>	<b>C1A24 NP RANGE</b> .....	<b>94</b>
<b>C1A00 CONTROL UNIT</b> .....	<b>70</b>	DTC Description .....	94
DTC Description .....	70	Diagnosis Procedure .....	94
Diagnosis Procedure .....	70	<b>C1A26 ECD MODE MALFUNCTION</b> .....	<b>96</b>
<b>C1A01 POWER SUPPLY CIRCUIT 1, C1A02</b>		DTC Description .....	96
<b>POWER SUPPLY CIRCUIT 2</b> .....	<b>71</b>	Diagnosis Procedure .....	96
DTC Description .....	71	<b>C1A27 ECD POWER SUPPLY CIRCUIT</b> .....	<b>98</b>
Diagnosis Procedure .....	71	DTC Description .....	98
<b>C1A03 VEHICLE SPEED SENSOR</b> .....	<b>72</b>	Diagnosis Procedure .....	98
DTC Description .....	72	<b>C1A39 STEERING ANGLE SENSOR</b> .....	<b>100</b>
Diagnosis Procedure .....	73	DTC Description .....	100
<b>C1A04 ABS/TCS/VDC SYSTEM</b> .....	<b>74</b>	Diagnosis Procedure .....	100
DTC Description .....	74	<b>C1B5D FEB OPE COUNT LIMIT</b> .....	<b>101</b>
Diagnosis Procedure .....	74	DTC Description .....	101
<b>C1A05 BRAKE SW/STOP LAMP SW</b> .....	<b>75</b>	Diagnosis Procedure .....	101
DTC Description .....	75	<b>C1A50 ADAS CONTROL UNIT</b> .....	<b>102</b>
Diagnosis Procedure .....	75	DTC Description .....	102
Component Inspection (Brake Pedal Position		Diagnosis Procedure .....	102
Switch) .....	78	<b>C10B7 YAW RATE SENSOR</b> .....	<b>103</b>
Component Inspection (Stop Lamp Switch) .....	78	DTC Description .....	103
<b>C1A06 OPERATION SW</b> .....	<b>79</b>	Diagnosis Procedure .....	103
DTC Description .....	79	<b>U0121 VDC CAN 2</b> .....	<b>104</b>
Diagnosis Procedure .....	79	DTC Description .....	104
Component Inspection .....	80	Diagnosis Procedure .....	104
<b>C1A12 LASER BEAM OFF CENTER</b> .....	<b>82</b>	<b>U0126 STRG SEN CAN 1</b> .....	<b>106</b>
DTC Description .....	82	DTC Description .....	106
Diagnosis Procedure .....	82	Diagnosis Procedure .....	106
<b>C1A13 STOP LAMP RELAY</b> .....	<b>83</b>	<b>U0401 ECM CAN 1</b> .....	<b>107</b>
DTC Description .....	83	DTC Description .....	107
<b>C1A14 ECM</b> .....	<b>85</b>	Diagnosis Procedure .....	107
DTC Description .....	85	<b>U0415 VDC CAN 1</b> .....	<b>108</b>
Diagnosis Procedure .....	85	DTC Description .....	108
<b>C1A15 GEAR POSITION</b> .....	<b>87</b>	Diagnosis Procedure .....	108
DTC Description .....	87	<b>U0428 STRG SEN CAN 2</b> .....	<b>110</b>
DTC Logic .....	87	DTC Description .....	110
Diagnosis Procedure .....	88		

Diagnosis Procedure .....	110	<b>ICC STEERING SWITCH (OTHER THAN MAIN SWITCH) DOES NOT FUNCTION</b> .....	124	A
<b>U1000 CAN COMM CIRCUIT</b> .....	111	Description .....	124	
DTC Description .....	111	Diagnosis Procedure .....	124	B
DTC Logic .....	111	<b>ICC SYSTEM DOES NOT CANCEL WHEN CVT SELECTOR LEVER SETS ON "N"</b> .....	125	C
Diagnosis Procedure .....	111	Description .....	125	
<b>U1010 CONTROL UNIT (CAN)</b> .....	112	Diagnosis Procedure .....	125	D
DTC Description .....	112	<b>CHIME DOES NOT SOUND</b> .....	126	
DTC Logic .....	112	Description .....	126	E
Diagnosis Procedure .....	112	Diagnosis Procedure .....	126	F
<b>POWER SUPPLY AND GROUND CIRCUIT</b> ...	113	<b>DRIVING FORCE IS HUNTING</b> .....	128	G
<b>ICC SENSOR</b> .....	113	Description .....	128	
ICC SENSOR : Diagnosis Procedure .....	113	Diagnosis Procedure .....	128	H
<b>C1A07 CVT</b> .....	114	<b>FREQUENTLY CANNOT DETECT THE VEHICLE AHEAD / DETECTION ZONE IS SHORT.</b> .....	129	I
DTC Description .....	114	Description .....	129	
Diagnosis Procedure .....	114	Diagnosis Procedure .....	129	J
<b>U153A CVT MESSAGE COUNTER FAILURE.</b> .....	115	<b>THE SYSTEM DOES NOT DETECT THE VEHICLE AHEAD AT ALL</b> .....	131	K
DTC Description .....	115	Description .....	131	
Diagnosis Procedure .....	115	Diagnosis Procedure .....	131	L
<b>U153B CVT CHECK SUM FAILURE</b> .....	116	<b>NORMAL OPERATING CONDITION</b> .....	133	
DTC Description .....	116	Description .....	133	
Diagnosis Procedure .....	116	<b>REMOVAL AND INSTALLATION</b> .....	136	
<b>C1A0C ADAS MESSAGE COUNTER FAILURE</b> .....	117	<b>ICC SENSOR</b> .....	136	
DTC Description .....	117	Exploded View .....	136	
Diagnosis Procedure .....	117	Removal and Installation .....	136	
<b>C1A0D MRR CAN FAILURE</b> .....	118	<b>ICC STEERING SWITCH</b> .....	138	
DTC Description .....	118	Exploded View .....	138	
Diagnosis Procedure .....	118	Removal and Installation .....	138	
<b>SYMPTOM DIAGNOSIS</b> .....	119	<b>ASCD</b>		
<b>INTELLIGENT CRUISE CONTROL SYSTEM SYMPTOMS</b> .....	119	<b>PRECAUTION</b> .....	140	
Symptom Table .....	119	<b>PRECAUTIONS</b> .....	140	
<b>MAIN SWITCH DOES NOT TURN ON, MAIN SWITCH DOES NOT TURN OFF</b> .....	120	Precaution for Supplemental Restraint System (SRS) "AIR BAG" and "SEAT BELT PRE-TENSIONER" .....	140	
Description .....	120	<b>SYSTEM DESCRIPTION</b> .....	141	
Diagnosis Procedure .....	120	<b>AUTOMATIC SPEED CONTROL DEVICE (ASCD)</b> .....	141	
<b>ICC SYSTEM CANNOT BE SET (MAIN SWITCH TURNS ON/OFF)</b> .....	122	Information .....	141	
Description .....	122			
Diagnosis Procedure .....	122			

## PRECAUTION

### PRECAUTIONS

#### Precaution for Supplemental Restraint System (SRS) "AIR BAG" and "SEAT BELT PRE-TENSIONER"

INFOID:000000011952912

The Supplemental Restraint System such as "AIR BAG" and "SEAT BELT PRE-TENSIONER", used along with a front seat belt, helps to reduce the risk or severity of injury to the driver and front passenger for certain types of collision. Information necessary to service the system safely is included in the SR and SB section of this Service Manual.

**WARNING:**

- To avoid rendering the SRS inoperative, which could increase the risk of personal injury or death in the event of a collision which would result in air bag inflation, all maintenance must be performed by an authorized NISSAN/INFINITI dealer.
- Improper maintenance, including incorrect removal and installation of the SRS, can lead to personal injury caused by unintentional activation of the system. For removal of Spiral Cable and Air Bag Module, see the SR section.
- Do not use electrical test equipment on any circuit related to the SRS unless instructed to in this Service Manual. SRS wiring harnesses can be identified by yellow and/or orange harnesses or harness connectors.

#### PRECAUTIONS WHEN USING POWER TOOLS (AIR OR ELECTRIC) AND HAMMERS

**WARNING:**

- When working near the Airbag Diagnosis Sensor Unit or other Airbag System sensors with the Ignition ON or engine running, DO NOT use air or electric power tools or strike near the sensor(s) with a hammer. Heavy vibration could activate the sensor(s) and deploy the air bag(s), possibly causing serious injury.
- When using air or electric power tools or hammers, always switch the Ignition OFF, disconnect the battery and wait at least three minutes before performing any service.

#### Precautions For Harness Repair

INFOID:000000011952913

ITS communication uses a twisted pair line. Be careful when repairing it.

- Solder the repaired area and wrap tape around the soldered area.

**NOTE:**

A fray of twisted lines must be within 110 mm (4.33 in).

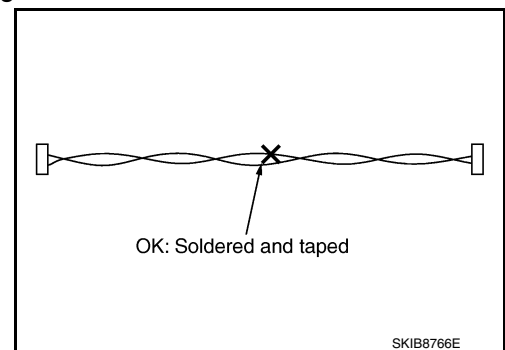

- Bypass connection is never allowed at the repaired area.

**NOTE:**

Bypass connection may cause ITS communication error. The spliced wire becomes separated and the characteristics of twisted line are lost.

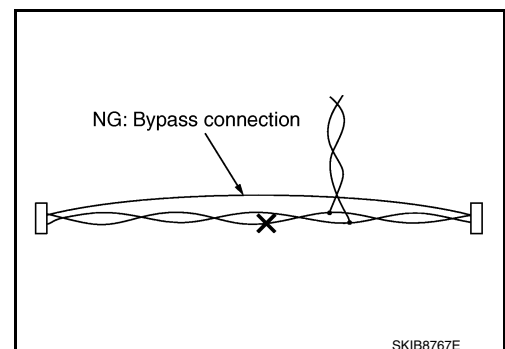

# PRECAUTIONS

< PRECAUTION >

[ICC]

## ICC System Service

INFOID:0000000011952914

### CAUTION:

- Turn the MAIN switch OFF in conditions similar to driving, such as free rollers or a chassis dynamometer.
- Never use the ICC sensor removed from vehicle. Never disassemble or remodel.
- Erase DTC when replacing parts of ICC system, then check the operation of ICC system after adjusting radar alignment if necessary.

A

B

C

D

E

F

G

H

I

J

K

L

M

N

CCS

P

# PREPARATION

< PREPARATION >

[ICC]

## PREPARATION

### PREPARATION

#### Special Service Tools

INFOID:000000011952915

The actual shape of the tools may differ from those illustrated here.

Tool number (TechMate No.) Tool name	Description
— (1-20-2851-1) ICC alignment kit	Adjusting ICC sensor
— (1-20-2722-1-IF) Wheel adaptor	Adjusting ICC sensor

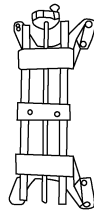
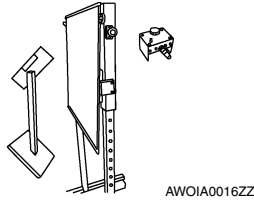

# COMPONENT PARTS

< SYSTEM DESCRIPTION >

[ICC]

## SYSTEM DESCRIPTION

### COMPONENT PARTS

#### Component Parts Location

INFOID:0000000011952916

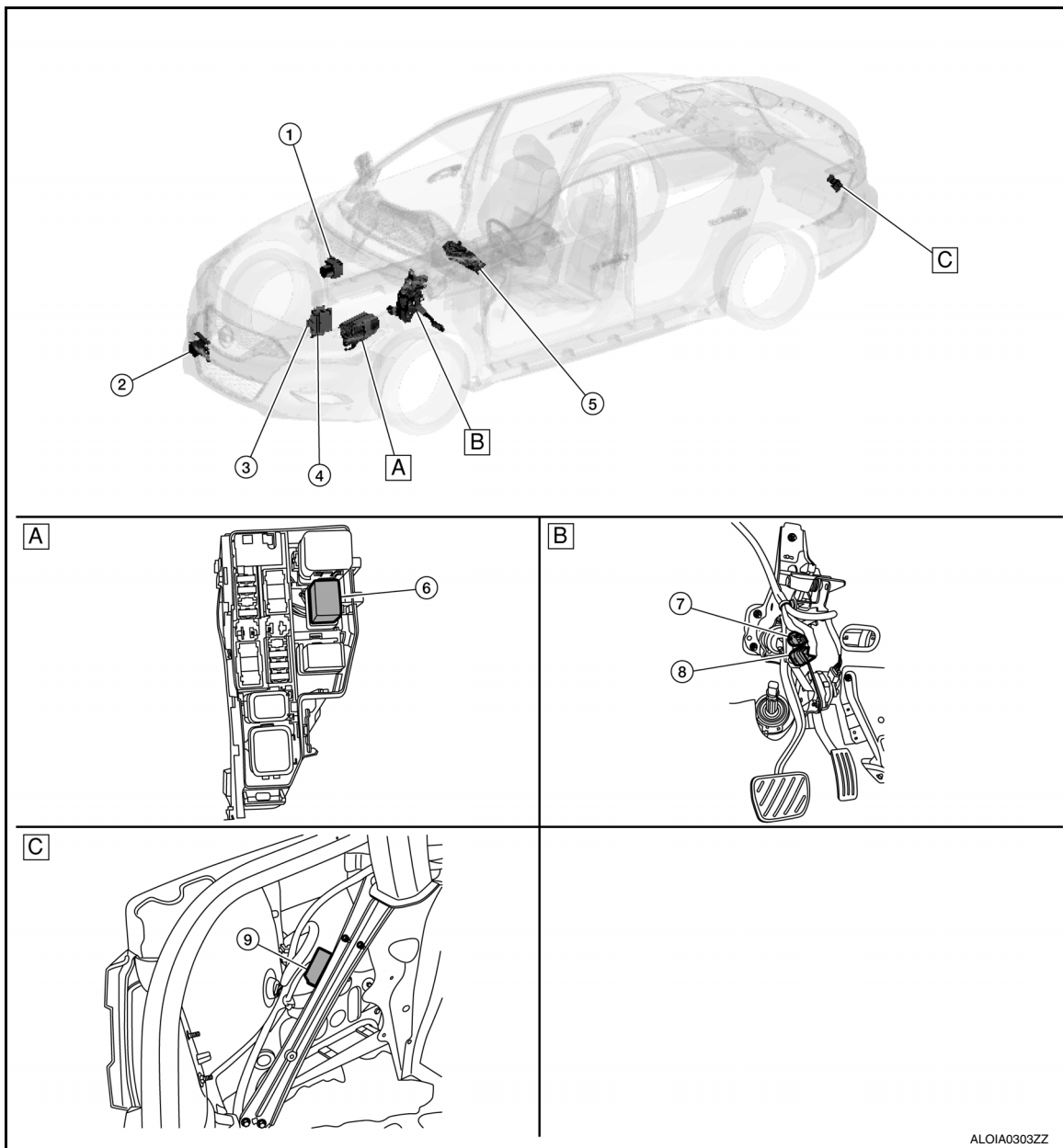

A. Engine room LH

B. Brake pedal area

C. Luggage compartment LH

CCS

# COMPONENT PARTS

< SYSTEM DESCRIPTION >

[ICC]

No.	Component	Function
1.	ABS actuator and electric unit (control unit)	<ul style="list-style-type: none"> <li>ABS actuator and electric unit (control unit) transmits the vehicle speed signal (wheel speed), stop lamp signal and VDC/TCS/ABS system operation condition to ADAS control unit via CAN communication.</li> <li>ABS actuator and electric unit (control unit) controls the brake based on a brake fluid pressure control signal received from the ADAS control unit via CAN communication. Refer to <a href="#">BRC-178, "Component Parts Location"</a> for detailed installation location.</li> </ul>
2.	ICC sensor	<ul style="list-style-type: none"> <li>Refer to <a href="#">CCS-8, "ICC Sensor"</a>.</li> </ul>
3.	TCM	<ul style="list-style-type: none"> <li>TCM transmits the signal related to CVT control to ADAS control unit via CAN communication.</li> <li>Refer to <a href="#">TM-12, "CVT CONTROL SYSTEM : Component Parts Location"</a> for detailed installation location.</li> </ul>
4.	ECM	<ul style="list-style-type: none"> <li>ECM transmits the accelerator pedal position signal, brake pedal position switch signal, stop lamp switch signal, ICC steering switch signal, etc., to ADAS control unit via CAN communication.</li> <li>ECM controls the electric throttle control actuator based on the engine torque demand received from the ADAS control unit via CAN communication.</li> <li>Refer to <a href="#">EC-15, "ENGINE CONTROL SYSTEM : Component Parts Location"</a> for detailed installation location.</li> </ul>
5.	Combination meter (Information display, FEB indicator lamp, buzzer)	<ul style="list-style-type: none"> <li>Description: Refer to <a href="#">CCS-10, "Combination Meter"</a>.</li> <li>System display and warning: Refer to <a href="#">CCS-18, "INTELLIGENT CRUISE CONTROL : Menu Displayed by Pressing Each Switch"</a>.</li> </ul>
6.	ICC brake hold relay	Refer to <a href="#">CCS-10, "ICC Brake Hold Relay"</a> .
7.	Brake pedal position switch	Refer to <a href="#">CCS-9, "Brake Pedal Position Switch/Stop Lamp Switch"</a> .
8.	Stop lamp switch	
9.	ADAS control unit	<ul style="list-style-type: none"> <li>Refer to <a href="#">CCS-9, "ADAS Control Unit"</a>.</li> <li>Refer to <a href="#">DAS-9, "Component Parts Location"</a> for detailed installation location.</li> </ul>

## ICC Sensor

INFOID:0000000011952917

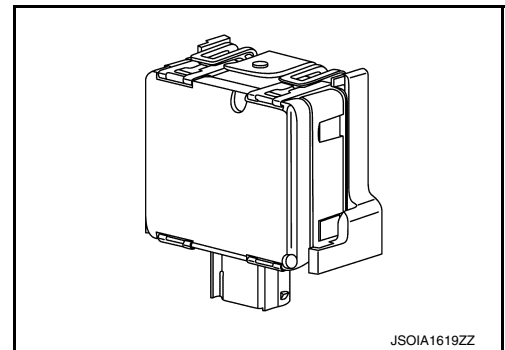

- ICC sensor is installed on the front of the bumper and detects a vehicle ahead using millimeter waves.
- ICC sensor detects radar reflected from a vehicle ahead by irradiating radar forward and calculates a distance from the vehicle ahead and relative speed, based on the detected signal.
- ICC sensor transmits information for ICC from the vehicle to ADAS control unit via ITS communication.



# COMPONENT PARTS

< SYSTEM DESCRIPTION >

[ICC]

## ADAS Control Unit

INFOID:0000000011952918

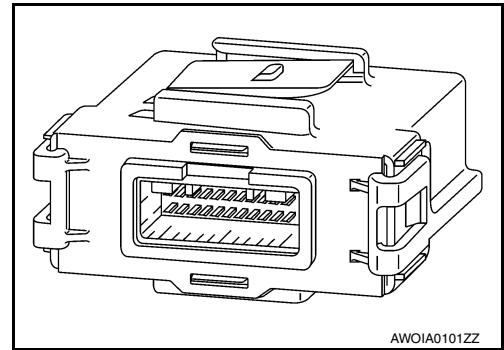

- ADAS control unit is installed.
- ADAS control unit calculates and transmits an engine torque command value to ECM and a brake fluid pressure control signal to ABS actuator and electric unit (control unit) via CAN communication.
- ADAS control unit transmits buzzer output signal and meter display signal to combination meter via CAN communication.

## Brake Pedal Position Switch/Stop Lamp Switch

INFOID:0000000011952919

### BRAKE PEDAL POSITION SWITCH

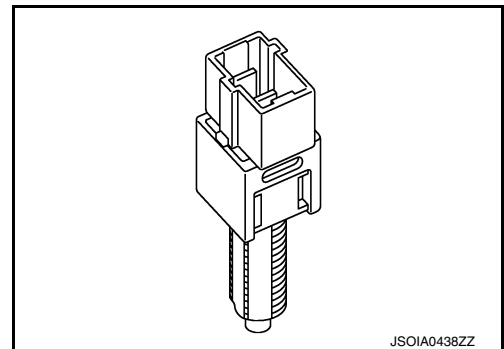

- Brake pedal position switch is installed at the upper part of the brake pedal and detects a brake operation performed by the driver.
- Brake pedal position switch is turned OFF when depressing the brake pedal.
- Brake pedal position switch signal is input to ECM. Brake pedal position switch signal is transmitted from ECM to ADAS control unit via CAN communication.

### STOP LAMP SWITCH

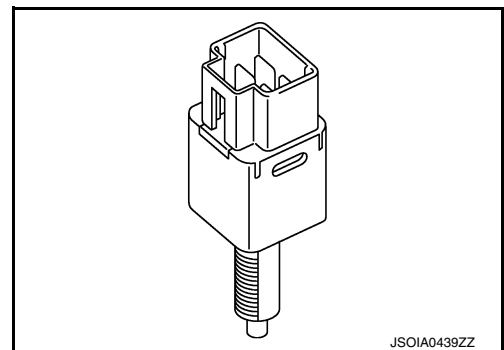

- Stop lamp switch is installed at the upper part of the brake pedal and detects a brake operation performed by the driver.
- Stop lamp switch is turned ON when depressing the brake pedal.
- Stop lamp switch signal is inputted to ECM and ABS actuator and electric unit (control unit). Stop lamp switch signals are transmitted from ECM and ABS actuator and electric unit (control unit) to ADAS control unit via CAN communication.

## ICC Steering Switch

INFOID:0000000011952920

- ICC steering switch is installed to the steering wheel and allows the driver to operate the ICC system by using this switch.

A  
B  
C  
D  
E  
F  
G  
H  
I  
J  
K  
L  
M  
N

CCS

P

# COMPONENT PARTS

## < SYSTEM DESCRIPTION >

[ICC]

- ICC steering switch controls the ON/OFF operation of the Intelligent Cruise Control and the settings of vehicle speed and distance between vehicles.
- ICC steering switch signal is transmitted to ECM. ECM transmits the signal to the ICC sensor unit via CAN communication.

## ICC Brake Hold Relay

INFOID:000000011952921

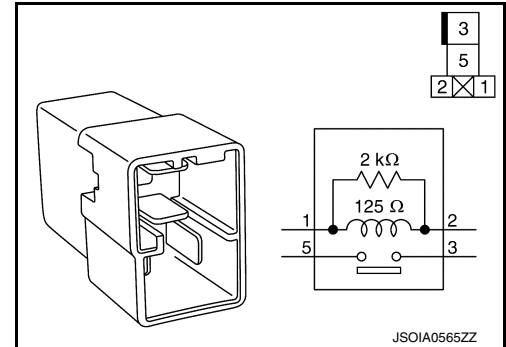

- ICC brake hold relay is installed in the engine room (LH).
- When the brake is activated by the ICC system, the ICC brake hold relay turns ON the stop lamp by bypassing the circuit of the stop lamp according to a signal transmitted from the ADAS control unit.

## Combination Meter

INFOID:000000011952922

- Performs the following operations using the signals received from the ADAS control unit via the CAN communication:
  - Displays the ICC system operation status using the meter display signal.
  - Illuminates the ICC system warning lamp using the ICC warning lamp signal.
  - Illuminates the FEB indicator lamp using the FEB indicator lamp signal.
  - Operates the buzzer (ICC warning chime) using the buzzer output signal.
- Combination meter turns ON/OFF the FEB system and transmits a system selection signal to the ICC sensor.

SYSTEM

System Description

INFOID:000000011952923

SYSTEM DIAGRAM

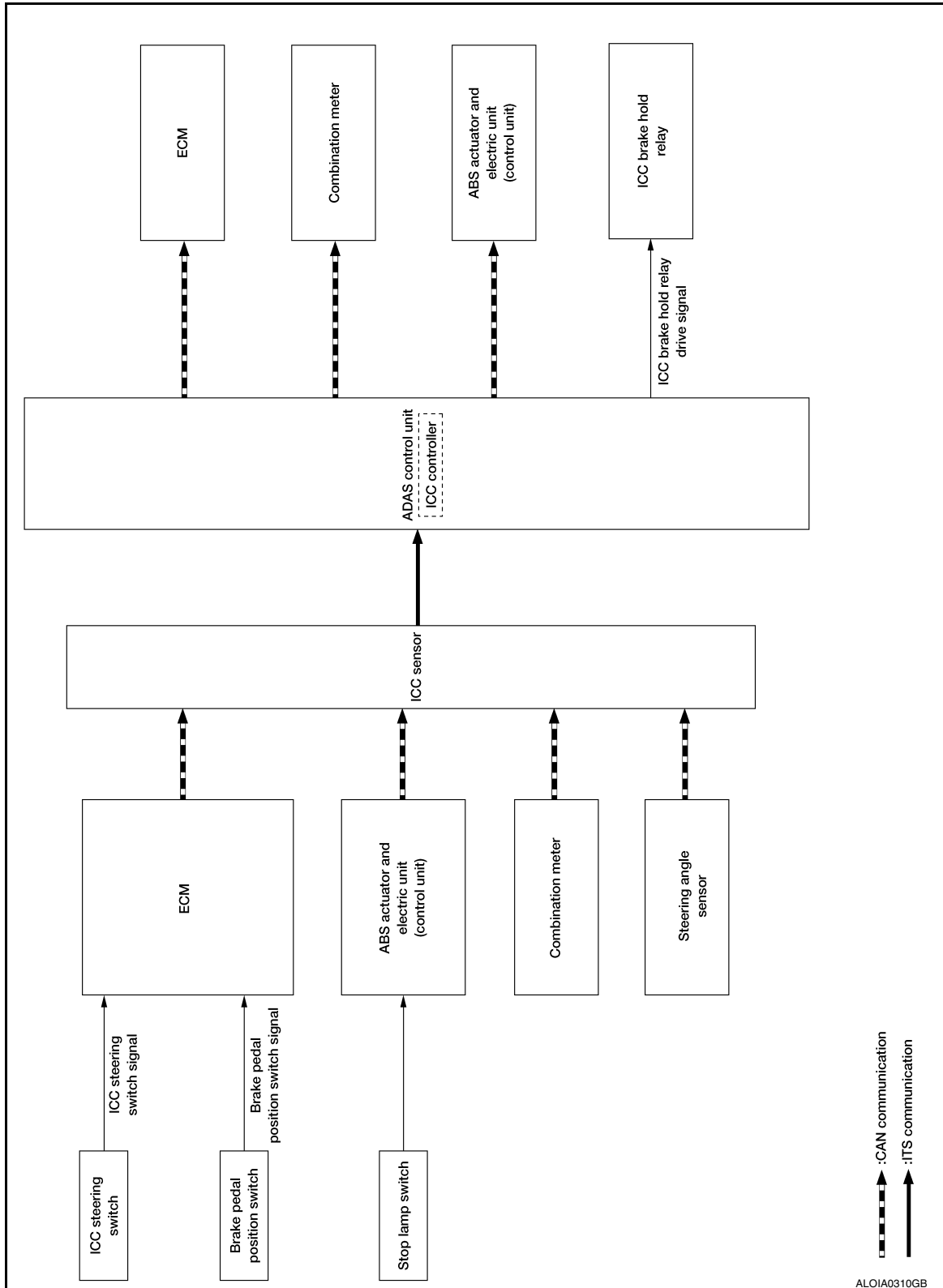

A  
B  
C  
D  
E  
F  
G  
H  
I  
J  
K  
L  
M  
N  
P

CCS

ICC SENSOR UNIT INPUT/OUTPUT SIGNAL ITEM

Input Signal Item

# SYSTEM

< SYSTEM DESCRIPTION >

[ICC]

Transmit unit	Signal name		Description	
ECM	CAN communication	Closed throttle position signal	Receives idle position state (ON/OFF)	
		Accelerator pedal position signal	Receives accelerator pedal position (angle)	
		ICC prohibition signal	Receives an operable/inoperable state of the ICC system	
		ICC steering switch signal	Main switch signal	Receives the operational state of the ICC steering switch
			SET/COAST switch signal	
			CANCEL switch signal	
			RESUME/ACCELERATE switch signal	
			DISTANCE switch signal	
		Engine speed signal	Receives engine speed	
Stop lamp switch signal	Receives an operational state of the brake pedal			
Brake pedal position switch signal	Receives an operational state of the brake pedal			
TCM	CAN communication	Input speed signal	Receives the number of revolutions of input shaft	
		Current gear position signal	Receives a current gear position	
		Shift position signal	Receives a selector lever position	
		Output shaft revolution signal	Receives the number of revolutions of output shaft	
ABS actuator and electric unit (control unit)	CAN communication	ABS malfunction signal	Receives a malfunction state of ABS	
		ABS operation signal	Receives an operational state of ABS	
		ABS warning lamp signal	Receives an ON/OFF state of ABS warning lamp	
		TCS malfunction signal	Receives a malfunction state of TCS	
		TCS operation signal	Receives an operational state of TCS	
		VDC OFF switch signal	Receives an ON/OFF state of VDC	
		VDC malfunction signal	Receives a malfunction state of VDC	
		VDC operation signal	Receives an operational state of VDC	
		Vehicle speed signal (ABS)	Receives wheel speeds of four wheels	
		Stop lamp switch signal	Receives an operational state of the brake pedal	
Yaw rate signal	Receives yaw rate acting on the vehicle			
Combination meter	CAN communication	Parking brake switch signal	Receives an operational state of the parking brake	
		System selection signal	Receives a selection state of FEB system	
Steering angle sensor	CAN communication	Steering angle sensor malfunction signal	Receives a malfunction state of steering angle sensor	
		Steering angle sensor signal	Receives the number of revolutions and turning direction of the steering wheel	
		Steering angle speed signal	Receives the turning angle speed of the steering wheel	
ADAS control unit	ITS communication	ADAS sensor signal	State of ADAS	

## Output Signal Item

Reception unit	Signal name		Description
ADAS control unit	ITS communication	ICC sensor signal	Transmits information for ICC

## ADAS CONTROL UNIT INPUT/OUTPUT SIGNAL ITEM

# SYSTEM

## < SYSTEM DESCRIPTION >

[ICC]

### Input Signal

Reception unit	Signal name		Description
ECM	CAN communication	Engine speed signal	Receives engine speed
		Accelerator pedal position signal	Receives accelerator pedal position (angle)
TCM	CAN communication	Input speed signal	Receives the number of revolutions of input shaft
		Output shaft revolution signal	Receives the number of revolutions of output shaft
ICC sensor	ITS communication	ICC sensor signal	Receives information for ICC

### Output Signal

Reception unit	Signal name		Description
ECM	CAN communication	ICC operation signal	Transmits an ICC operation signal necessary for Intelligent Cruise Control
TCM	CAN communication	ICC operation signal	Transmits an ICC operation signal necessary for Intelligent Cruise Control via ECM
ABS actuator and electric unit (control unit)	CAN communication	Brake fluid pressure control signal	Transmits a brake fluid pressure control signal to activate the brake
Combination meter	CAN communication	Meter display signal	ICC warning lamp signal
			Vehicle ahead detection indicator signal
			Set vehicle speed indicator signal
			Set distance indicator signal
			SET switch indicator signal
			MAIN switch indicator signal
			Transmits a signal to display a state of the system on the information display
		FEB indicator lamp signal	<ul style="list-style-type: none"> <li>Transmits a signal to turn ON the FEB indicator lamp</li> <li>Transmits an ON/OFF state of the FEB system</li> </ul>
		Buzzer output signal	Transmits a buzzer output signal to turn ON the buzzer of the following systems: <ul style="list-style-type: none"> <li>Intelligent Cruise Control (ICC)</li> <li>Forward Emergency Braking (FEB)</li> </ul>
ICC sensor	ITS communication	ADAS status signal	State of ADAS
ICC brake hold relay	ICC brake hold relay drive signal		Activates the brake hold relay and turns ON the stop lamp

### DESCRIPTION

#### Intelligent Cruise Control

The Intelligent Cruise Control (ICC) system maintains a selected distance from the vehicle in front of own vehicle within the speed range of 0 to 144 km/h (0 to 90 MPH) up to the set speed.

The set speed can be selected by the driver between 32 to 144 km/h (20 to 90 MPH).

The vehicle travels at a set speed when the road ahead is clear.

**CAUTION:**

**Never set the cruise speed to exceed the posted speed limit.**

**WARNING:**

A  
B  
C  
D  
E  
F  
G  
H  
I  
J  
K  
L  
M  
N

CCS

P

# SYSTEM

< SYSTEM DESCRIPTION >

[ICC]

**Always drive carefully and attentively when using either cruise control mode. To avoid serious injury or death, do not rely on the system to prevent accidents or to control the vehicle's speed in emergency situations. Do not use cruise control except in appropriate road and traffic conditions.**

Forward Collision Warning (FCW) System

FCW shares the systems and components with ICC system. Refer to [CCS-11, "System Description"](#).

Forward Emergency Braking (FEB) System

FEB system shares the systems and components with ICC system. Refer to [BRC-184, "System Description"](#).

## Fail-safe (ADAS Control Unit)

INFOID:000000011952924

If a malfunction occurs in each system, ADAS control unit cancels each control, sounds a beep, and turns ON the warning lamp or indicator lamp.

System	Buzzer	Warning lamp/Indicator lamp	Description
Intelligent Cruise Control System	High-pitched tone	ICC system warning lamp	Cancel

## Fail-safe (ICC Sensor)

INFOID:000000011952925

If a malfunction occurs in the ICC sensor, ADAS control unit cancels control, sounds a beep, and turns ON the ICC system warning lamp in the combination meter.

## INTELLIGENT CRUISE CONTROL

SYSTEM DIAGRAM

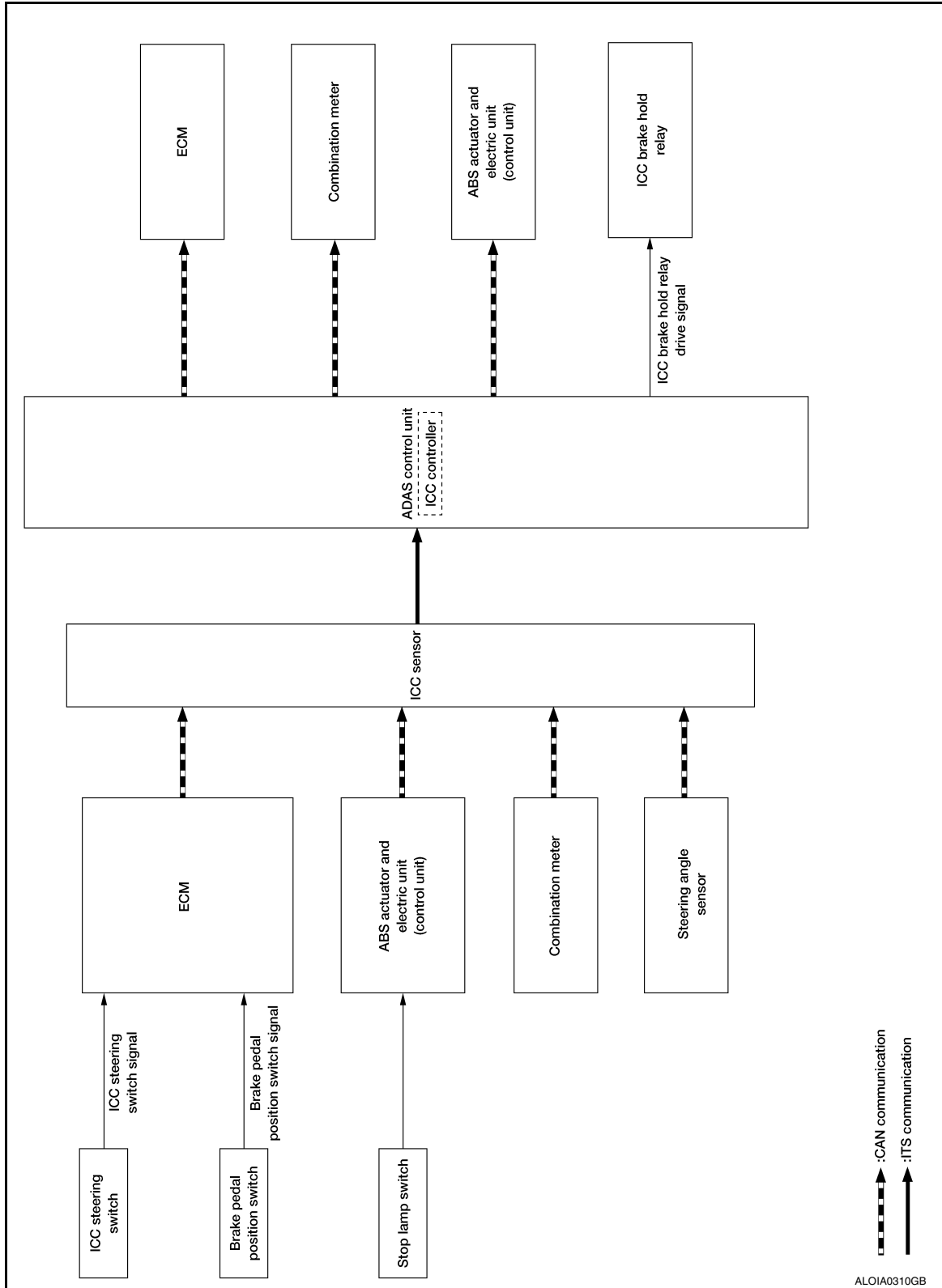

A  
B  
C  
D  
E  
F  
G  
H  
I  
J  
K  
L  
M  
N  
P

CCS

FUNCTION DESCRIPTION

The Intelligent Cruise Control (ICC) system automatically maintains a selected distance from the vehicle traveling in front of own vehicle according to that vehicle's speed (up to the set speed) or at the set speed when the road ahead is clear.

# SYSTEM

[ICC]

## < SYSTEM DESCRIPTION >

With ICC system, the driver can maintain the same speed as other vehicles without the constant need to adjust the set speed as the driver would with a normal cruise control system.

The following items are controlled in the ICC system:

- When there are no vehicles traveling ahead, the ICC system maintains the speed set by the driver. The set speed range is between approximately 32 and 144 km/h (20 and 90 MPH).
- When there is a vehicle traveling ahead, the ICC system adjusts the speed to maintain the distance, selected by driver, from a vehicle ahead. The adjusting speed range is up to the set speed.
- When the vehicle traveling ahead has moved from its lane of travel, the ICC system accelerates and maintains vehicle speed up to the set speed.

### **CAUTION:**

**If the vehicle ahead comes to a stop, the vehicle decelerates to a standstill within the limitations of the system. The system will cancel once it judges that the vehicle has come to a standstill and sound a warning chime.**

**To prevent the vehicle from moving, the driver must depress the brake pedal.**

### **NOTE:**

When the accelerator pedal is depressed, the brake operation and the warning are not performed by the ICC system.

## OPERATION DESCRIPTION

Push and release the MAIN switch ON.

The MAIN switch indicator, set distance indicator and set vehicle speed indicator come on and ICC system is set to a standby state.

ADAS control unit performs the control as per the following:

Constant speed	Comparing the set vehicle speed with the current vehicle speed, it transmits the command to ECM via CAN communication to reach the set vehicle speed and controls the electric throttle control actuator.
Deceleration	When a vehicle ahead (slower than driver set vehicle speed) appears or when a vehicle ahead slows down, the system controls the electric throttle control actuator into the close direction and decelerates the vehicle. If greater deceleration is necessary, the system transmits the brake fluid pressure control signal to the ABS actuator and electric unit (control unit) via CAN communication and operates the brake.
Following	The system controls the electric throttle control actuator and the brake fluid pressure to keep the proper distance between the vehicles according to the vehicle speed change of the vehicle ahead.
Acceleration	When a vehicle ahead is not detected because it changes lanes or own vehicle changes lanes during the following driving, the system controls the electric throttle control actuator to the open direction and accelerates the vehicle to the set vehicle speed slowly.

### Set Condition

Under a standby state, pushing down the SET/COAST switch will start system control.

- When vehicle speed is between approximately 32 km/h and 144 km/h (20 MPH and 90 MPH).
- When vehicle speed is below approximately 32 km/h (20 MPH) if a vehicle ahead is detected. The set vehicle speed becomes 32 km/h (20 MPH).

If the system is canceled by conditions 1-6 below, the system will resume control at the last set cruising speed by pushing up the RESUME/ACCELERATE switch.

### **NOTE:**

- When the SET/COAST switch is pushed under the following conditions, the system cannot be set and the set vehicle speed indicator will blink for approximately 2 seconds:
  - When traveling below 32 km/h (20 MPH) and the vehicle ahead is not detected.
  - When the selector lever is not in the "D" position or manual mode.
  - When the parking brake is applied.
  - When the brakes are operated by the driver.
- When the SET/COAST switch is pushed under the following conditions, the system cannot be set and a warning chime will sound and display causes in combination meter (information display):
  - When the VDC is OFF. (To use the ICC system, turn ON the VDC system, push the MAIN switch to turn OFF the ICC system and reset the ICC system by pushing the MAIN switch again.)
  - When ABS or VDC (including the TCS) operates.
  - When the wheel is slipping. (To use the ICC system, make sure the wheels are no longer spinning, push the MAIN switch to turn OFF the ICC system and reset the ICC system by pushing the MAIN switch again.)

### Cancel Conditions

1. When CANCEL switch is pressed.
2. When brake pedal is depressed.
3. When the vehicle ahead is not detected below the speed of 24 km/h (15 MPH).



# SYSTEM

## < SYSTEM DESCRIPTION >

[ICC]

4. When the selector lever is not in the "D" position or manual mode.
5. When the parking brake is applied.
6. When the system judges the vehicle is at a standstill.
7. When ABS or VDC (including the TCS) operates.
8. When the MAIN switch is turned OFF.
9. When a wheel slips.
10. When the VDC is turned OFF.
11. When a system malfunction occurs.

A

B

C

D

E

F

G

H

I

J

K

L

M

N

CCS

P

OPERATION  
INTELLIGENT CRUISE CONTROL

INTELLIGENT CRUISE CONTROL : Switch Name and Function

INFOID:000000011952928

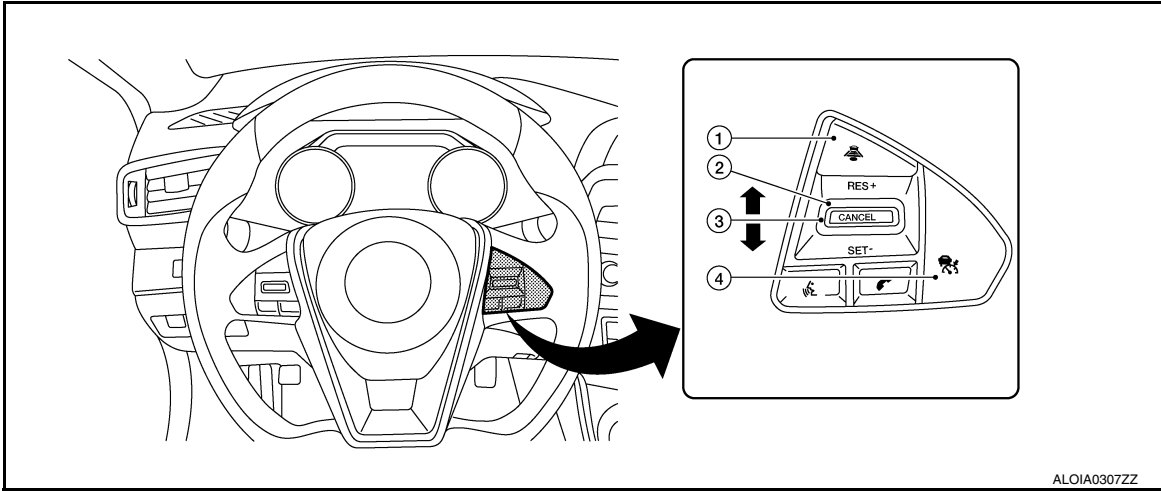

No.	Switch name	Description
1.	DISTANCE switch	Changes the following distance from: Long, Middle, Short
2.	CANCEL switch	Deactivates the system without erasing the set speed
3.	RES/+ SET-/- switch	Sets desired cruise speed or reduces speed incrementally <ul style="list-style-type: none"> <li>• Push and hold the switch to decrease the set speed by 8 km/h (5 MPH).</li> <li>• Push then quickly release the switch to decrease the set speed by 1.6 km/h (1 MPH).</li> </ul> <b>NOTE:</b> The minimum set speed is 32 km/h (20 MPH). Resumes set speed or increases speed incrementally <ul style="list-style-type: none"> <li>• Push and hold the switch to increase the set speed by 8 km/h (5 MPH).</li> <li>• Push then quickly release the switch to increase the set speed by 1.6 km/h (1 MPH).</li> </ul>
4.	MAIN switch	Master switch to activate the system (Press for less than 1.5 seconds.)

INTELLIGENT CRUISE CONTROL : Menu Displayed by Pressing Each Switch

INFOID:000000011952929

ICC SYSTEM DISPLAY (ON THE INFORMATION DISPLAY)

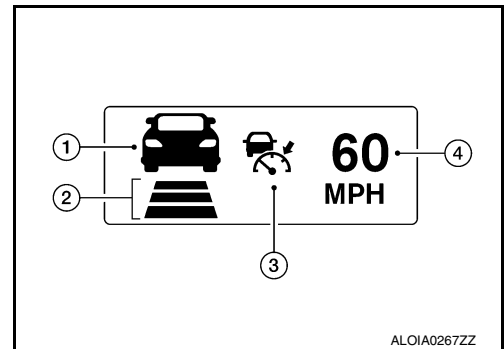

No.	Display item	Description
1.	Vehicle ahead detection indicator	Indicates whether it detects a vehicle ahead
2.	Set distance indicator	Indicates the selected distance between vehicles set with the DISTANCE switch
3.	Main switch indicator (white)	White: Indicates the main switch is ON (ICC system ON)
	ICC system warning lamp (orange)	Orange: Indicates that a malfunction occurred in the ICC system
4.	Set vehicle speed indicator	<ul style="list-style-type: none"> <li>• Indicates the set vehicle speed</li> <li>• Indicates 32 km/h (20 MPH) when setting is less than 32 km/h (20 MPH)</li> </ul>





# OPERATION

< SYSTEM DESCRIPTION >

[ICC]

## SYSTEM CONTROL CONDITION DISPLAY

Push and hold the ICC MAIN switch for longer than approximately 1.5 seconds. This mode will be in a standby state for setting.

Condition		Display on ICC system display
Standby mode		 <small>ALOIA0269ZZ</small>
Control mode	Without a vehicle ahead	Set vehicle distance (Long)  <small>ALOIA0268ZZ</small>
		Set vehicle distance (Middle)  <small>AWOIA0131ZZ</small>
		Set vehicle distance (Short)  <small>AWOIA0132ZZ</small>
		When the vehicle speed exceeds the set speed  <small>ALOIA0273ZZ</small>

A  
B  
C  
D  
E  
F  
G  
H  
I  
J  
K  
L  
M  
N



CCS

P

# OPERATION

< SYSTEM DESCRIPTION >

[ICC]

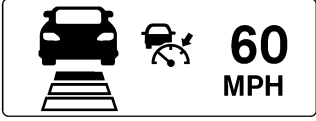
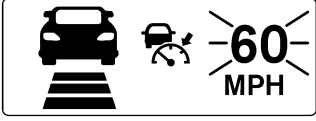
		Condition	Display on ICC system display
Control mode	With a vehicle ahead	Set vehicle distance (Long)	 <small>ALOIA0274ZZ</small>
		Set vehicle distance (Middle)	 <small>AWOIA0133ZZ</small>
		Set vehicle distance (Short)	 <small>AWOIA0134ZZ</small>
		When the vehicle speed exceeds the set speed	 <small>ALOIA0272ZZ</small>

## APPROACH WARNING DISPLAY

If own vehicle comes closer to a vehicle ahead due to rapid deceleration of that vehicle or if another vehicle cuts in, the system warns the driver with the chime and ICC system display. Decelerate by depressing the brake pedal to maintain a safe vehicle distance if:

- The chime sounds.
- The vehicle ahead detection indicator blinks in orange.

The warning chime may not sound in some cases when there is a short distance between vehicles. Some examples are:

- When the vehicles are traveling at the same speed and the distance between vehicles is not changing.
- When the vehicle ahead is traveling faster and the distance between vehicles is increasing.
- When a vehicle cuts in near own vehicle.

The warning chime will not sound when own vehicle approaches vehicles that are parked or moving slowly.

The warning chime will not sound when the accelerator pedal is depressed, overriding the system.

The approach warning chime may sound and the system display may blink when the ICC sensor detects some reflectors which are fitted on vehicles in other lanes or on the side of the road.

This may cause the ICC system to decelerate or accelerate the vehicle.

The ICC sensor may detect these objects when the vehicle is driven on winding roads, hilly roads or when entering or exiting a curve.

The ICC sensor may also detect reflectors on narrow roads or in road construction zones.

In these cases, driver will have to manually control the proper distance ahead of own vehicle.

Also, the sensor sensitivity can be affected by vehicle operation (steering maneuver or driving position in the lane) or traffic or vehicle conditions (for example, if a vehicle is being driven with some damage).



# OPERATION

< SYSTEM DESCRIPTION >

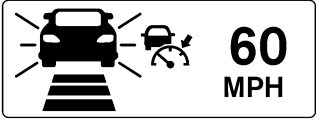
[ICC]

Condition	Display on ICC system display
<p>When own vehicle comes closer to the vehicle ahead and it is judged that the distance between the vehicles is not sufficient</p>	 <p style="text-align: right; font-size: small;">ALOIA0277ZZ</p>

## WARNING LAMP AND AUTOMATIC CANCELLATION DISPLAY

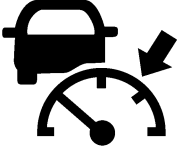
Condition	Description	Display on ICC system display
<p>Automatic cancellation display</p> <ul style="list-style-type: none"> <li>When brake pedal is depressed</li> <li>When CANCEL switch is pressed</li> <li>When a vehicle ahead is not detected below the speed of 24 km/h (15 MPH)</li> <li>When the system judges the vehicle is at a standstill</li> <li>When the selector lever is not in "D" position or manual mode</li> <li>When the parking brake is applied</li> </ul>	<p>A chime sounds and the control is automatically canceled.</p> <p><b>NOTE:</b></p> <ul style="list-style-type: none"> <li>The system will be in a standby state after the control is automatically canceled.</li> <li>A chime sounds when the control is automatically canceled except when brake pedal is depressed or when CANCEL switch is pressed.</li> </ul>	 <p style="text-align: right; font-size: small;">ALOIA0269ZZ</p>
<p>Warning display</p> <ul style="list-style-type: none"> <li>When the VDC is turned OFF</li> <li>When the VDC or ABS (including the TCS) operates</li> <li>When a wheel slips</li> <li>When the driver mode selector (DMS) switch is in SNOW mode</li> </ul>	<p>A chime sounds and the control is automatically canceled.</p> <p><b>NOTE:</b></p> <p>When the conditions listed are no longer present, turn the system OFF using the MAIN switch. Turn the ICC system back on to use the system.</p>	<p>Example: When the front bumper near the ICC sensor is blocked or dirty, making it impossible to detect a vehicle ahead</p> <p> Unavailable Front radar obstruction</p> <p style="text-align: center;">↓</p>  <p style="text-align: right; font-size: small;">ALOIA0278ZZ</p>
<p>When the ICC system is malfunctioning</p>	<p>A chime sounds and the control is automatically canceled.</p> <p><b>NOTE:</b></p> <p>Turn the engine OFF and restart engine. If there is no malfunction, it is possible to set the system.</p>	 <p style="text-align: right; font-size: small;">ALOIA0279ZZ</p>

**NOTE:**  
When the ICC system is automatically canceled, the cancellation condition can be displayed in "Work support" of CONSULT (ICC/ADAS).

A  
B  
C  
D  
E  
F  
G  
H  
I  
J  
K  
L  
M  
N  
P

CCS

## HANDLING PRECAUTION

### Precautions for Intelligent Cruise Control

INFOID:000000011952932

- ICC system is only an aid to assist the driver and is not a collision warning or avoidance system. It is the driver's responsibility to stay alert, drive safely and be in control of the vehicle at all times.
- The system is primarily intended for use on straight, dry, open roads with light traffic. It is not advisable to use the system in city traffic or congested areas.
- This system will not adapt automatically to road conditions. This system should be used in evenly flowing traffic. Never use the system on roads with sharp curves or on icy roads, in heavy rain or in fog.
- The ICC sensor will not detect the following objects:
  - Stationary and slow-moving vehicles.
  - Pedestrians or objects in the roadway.
  - Oncoming vehicles in the same lane.
  - Motorcycles traveling offset in the travel lane.
- As there is a performance limit to the distance control function, never rely solely on the ICC system. This system does not correct careless, inattentive or absent-minded driving or overcome poor visibility in rain, fog, or other bad weather. Decelerate the vehicle speed by depressing the brake pedal, depending on the distance to the vehicle ahead and the surrounding circumstances in order to maintain a safe distance between vehicles.
- If the vehicle ahead comes to a stop, the vehicle decelerates to a standstill within the limitations of the system. The system will cancel once it judges that the vehicle has come to a standstill and sound a warning chime. To prevent the vehicle from moving, the driver must depress the brake pedal.
- The system may not detect the vehicle ahead of the driver in certain road or weather conditions. To avoid accidents, never use the ICC system under the following conditions:
  - On roads where the traffic is heavy or there are sharp curves.
  - On slippery road surfaces such as on ice or snow, etc.
  - During bad weather (rain, fog, snow, etc.).
  - When rain, snow or dirt adheres to the ICC sensor.
  - On steep downhill roads (the vehicle may go beyond the set vehicle speed and frequent braking may result in overheating the brakes).
  - On repeated uphill and downhill roads.
  - When traffic conditions make it difficult to keep a proper distance between vehicles because of frequent acceleration or deceleration.
  - Never use the ICC system if own vehicle is towing a trailer. The system may not detect a vehicle ahead.
  - Interference by other radar sources.
- In some road or traffic conditions, a vehicle or object can unexpectedly come into the sensor detection zone and cause automatic braking. The driver may need to control the distance from other vehicles using the accelerator pedal. Always stay alert and avoid using the ICC system when it is not recommended in this section.
- The Intelligent Cruise Control uses a sensor located on the front of the vehicle to detect vehicles traveling ahead. The sensor generally detects the signals returned from the vehicle ahead. Therefore, if the sensor cannot detect the reflection from the vehicle ahead, the ICC system may not maintain the selected distance.
- The following are some conditions in which the sensor cannot detect the signals:
  - When snow or road spray from traveling vehicles reduces the sensor's visibility.
  - When excessively heavy baggage is loaded in the rear seat or the luggage room of own vehicle.
- The ICC system is designed to automatically check the sensor's operation within the limitations of the system. When the sensor area around the ICC sensor is covered with dirt or is obstructed, the system will automatically cancel. If the sensor area around the ICC sensor is covered with ice, a transparent or translucent vinyl bag, etc., the ICC system may not detect it. In these instances, the Intelligent Cruise Control may not cancel and may not be able to maintain the selected following distance from the vehicle ahead. Be sure to check and clean the sensor area around the ICC sensor regularly.
- The ICC system does not control vehicle speed or warn the driver when own vehicle approaches stationary or slow-moving vehicles. The driver must pay attention to vehicle operation to maintain proper distance from vehicles ahead when approaching toll gates or traffic congestion.

# HANDLING PRECAUTION

[ICC]

## < SYSTEM DESCRIPTION >

- The detection zone of the ICC sensor is limited. A vehicle ahead must be in the detection zone for the Intelligent Cruise Control to maintain the selected distance from the vehicle ahead. A vehicle ahead may move outside of the detection zone due to its position within the same lane of travel. Motorcycles may not be detected in the same lane ahead if they are traveling offset from the center line of the lane. A vehicle that is entering the lane ahead may not be detected until the vehicle has completely moved into the lane. If this occurs, the ICC system may warn the driver by blinking the system indicator and sounding the chime. The driver may have to manually control the proper distance from vehicle traveling ahead.

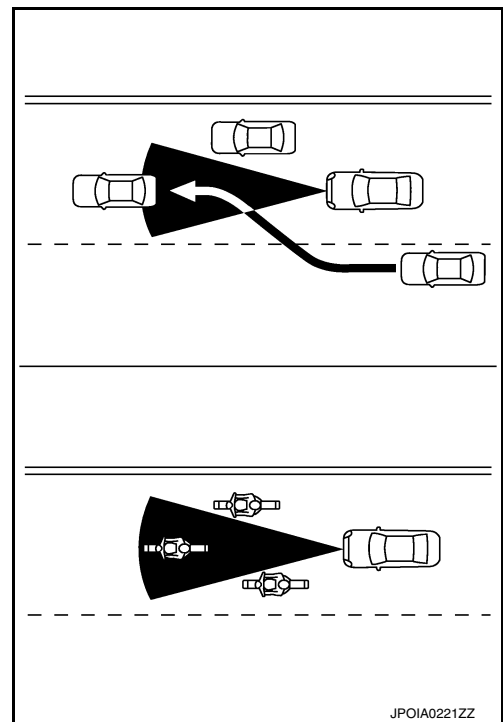

A  
B  
C  
D  
E  
F  
G

- When driving on some roads, such as winding, hilly, curved, narrow roads or roads which are under construction, the ICC sensor may detect vehicles in a different lane or may temporarily not detect a vehicle traveling ahead. This may cause the ICC system to decelerate or accelerate the vehicle. The detection of vehicles may also be affected by vehicle operation (steering maneuver or traveling position in the lane, etc.) or vehicle condition. If this occurs, the ICC system may warn the driver by blinking the system indicator and sounding the chime unexpectedly. The driver will have to manually control the proper distance away from the vehicle traveling ahead.

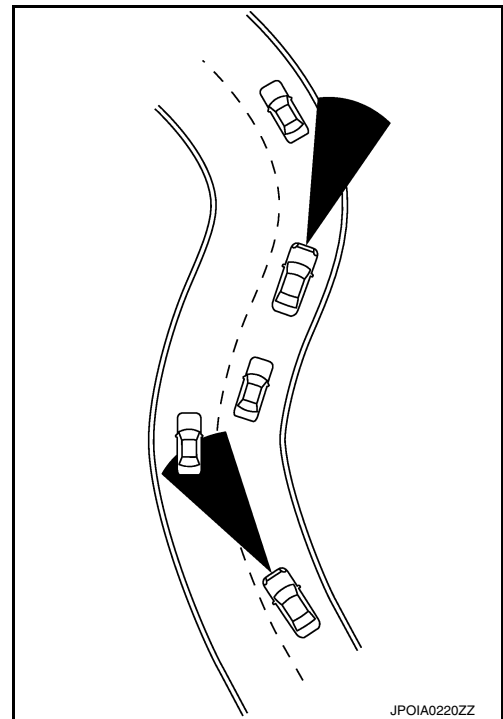

H  
I  
J  
K  
L  
M  
N

- When driving on the freeway at a set speed and approaching a slower traveling vehicle ahead, the ICC will adjust the speed to maintain the distance, selected by the driver, from the vehicle ahead. If the vehicle ahead changes lanes or exits the freeway, the ICC system will accelerate and maintain the speed up to the set speed. Pay attention to the driving operation to maintain control of the vehicle as it accelerates to the set speed. The vehicle may not maintain the set speed on winding or hilly roads. If this occurs, the driver will have to manually control the vehicle speed.

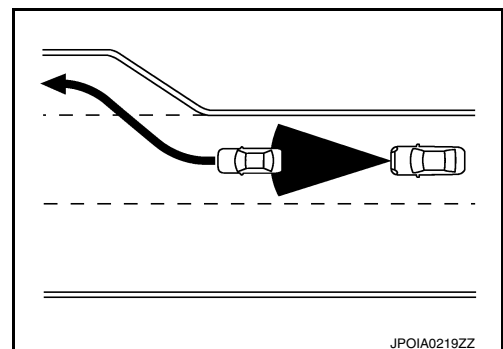

CCS  
P

## HANDLING PRECAUTION

< SYSTEM DESCRIPTION >

[ICC]

- Normally when controlling the distance to a vehicle ahead, this system automatically accelerates or decelerates own vehicle according to the speed of the vehicle ahead. Depress the accelerator to properly accelerate own vehicle when acceleration is required for a lane change. Depress the brake pedal when deceleration is required to maintain a safe distance to the vehicle ahead due to its sudden braking or if a vehicle cuts in. Always stay alert when using the ICC system.
- The sensor sensitivity can be affected by vehicle operation (steering maneuver or driving position in the lane) or traffic or vehicle conditions (for example, if a vehicle is being driven with some damage).



# DIAGNOSIS SYSTEM (ADAS CONTROL UNIT)

< SYSTEM DESCRIPTION >

[ICC]

## DIAGNOSIS SYSTEM (ADAS CONTROL UNIT)

### CONSULT Function (ICC/ADAS)

INFOID:0000000011952934

#### APPLICATION ITEMS

CONSULT performs the following functions via CAN communication using ADAS control unit:

Diagnosis mode	Description
Configuration	<ul style="list-style-type: none"> <li>The vehicle specification that is written in ADAS control unit can be displayed or stored.</li> <li>The vehicle specification can be written when ADAS control unit is replaced.</li> </ul>
Work support	Displays causes of automatic system cancellation that occurred during system control.
Self Diagnostic Result	Displays the name of a malfunctioning system stored in the ADAS control unit.
Data Monitor	Displays ADAS control unit input/output data in real time.
Active Test	Enables an operational check of a load by transmitting a driving signal from the ADAS control unit to the load.
ECU Identification	Displays ADAS control unit part number.
CAN Diag Support Monitor	Displays a reception/transmission state of CAN communication and ITS communication.

#### CONFIGURATION

Configuration includes functions as follows:

Function	Description
Read/Write Configuration	Before Replace ECU Allows the reading of vehicle specification written in ADAS control unit to store the specification in CONSULT.
	After Replace ECU Allows the writing of the vehicle information stored in CONSULT into the ADAS control unit.
Manual Configuration	Allows the writing of the vehicle specification into the ADAS control unit by hand.

#### WORK SUPPORT

Work support items	Description
CAUSE OF AUTO-CANCEL 5	Displays causes of automatic system cancellation that occurred during control of the Intelligent Cruise Control (ICC).

#### NOTE:

- Causes of the maximum five cancellations (system cancel) are displayed.
- The displayed cancellation causes display the number of the ignition switch ON/OFF up to 254. It is fixed to 254 if it is over 254. It returns to 0 when the same cancellation cause is detected again.

Display Items for the Cause of Automatic Cancellation 1

Cause of cancellation	Intelligent Cruise Control (ICC)	Description
CAN COMM ERROR	×	ADAS control unit received an abnormal signal with CAN communication.
NO RECORD	×	—

#### SELF DIAGNOSTIC RESULT

Refer to [DAS-25. "DTC Index"](#).

A  
B  
C  
D  
E  
F  
G  
H  
I  
J  
K  
L  
M  
N  
P



# DIAGNOSIS SYSTEM (ADAS CONTROL UNIT)

[ICC]

< SYSTEM DESCRIPTION >

**NOTE:**

- The details of time display are as per the following:
  - CRNT: A malfunction is detected now.
  - PAST: A malfunction was detected in the past.
- ODO/TRIP METER (Mileage) and VOLTAGE (IGN voltage) are displayed on FFD (Freeze Frame Data).

**DATA MONITOR**

**NOTE:**

The following table includes information (items) inapplicable to this vehicle. For information (items) applicable to this vehicle, refer to CONSULT display items.

Monitored item [Unit]	ALL SIG (ICC)	MAIN SIG (ICC)	MAIN SIG (BSW)	Description
MAIN SW [On/Off]	×	×	×	Indicates [ON/OFF] status as judged from ICC steering switch.
SET/COAST SW [On/Off]	×	×		Indicates [ON/OFF] status as judged from ICC steering switch.
CANCEL SW [On/Off]	×	×		Indicates [ON/OFF] status as judged from ICC steering switch.
RESUME/ACC SW [On/Off]	×	×		Indicates [ON/OFF] status as judged from ICC steering switch.
DISTANCE SW [On/Off]	×			Indicates [ON/OFF] status as judged from ICC steering switch.
CRUISE OPE [On/Off]	×	×		Indicates whether controlling or not (ON means “controlling”).
BRAKE SW [On/Off]	×	×	×	Indicates [ON/OFF] status as judged from ICC brake switch signal (ECM transmits ICC brake switch signal through CAN communication).
STOP LAMP SW [On/Off]	×	×	×	Indicates [ON/OFF] status as judged from stop lamp switch signal (ECM transmits stop lamp switch signal through CAN communication).
IDLE SW [On/Off]	×			Indicates [ON/OFF] status of idle switch read from ADAS control unit through CAN communication (ECM transmits ON/OFF status through CAN communication).
SET DISTANCE [Short/Mid/Long]	×	×		Indicates set distance memorized in ADAS control unit.
CRUISE LAMP [On/Off]	×	×		Indicates [ON/OFF] status of MAIN switch indicator output.
OWN VHCL [On/Off]	×			<b>NOTE:</b> The item is displayed, but it is not monitored.
VHCL AHEAD [On/Off]	×			Indicates [ON/OFF] status of vehicle ahead detection indicator output.
ICC WARNING [On/Off]	×			Indicates [ON/OFF] status of ICC system warning lamp output.
VHCL SPEED SE [km/h] or [mph]	×	×	×	Indicates vehicle speed calculated from ADAS control unit through CAN communication [ABS actuator and electric unit (control unit) transmits vehicle speed signal (wheel speed) through CAN communication].
SET VHCL SPD [km/h] or [mph]	×	×		Indicates set vehicle speed memorized in ADAS control unit.
BUZZER O/P [On/Off]	×			Indicates [ON/OFF] status of ICC warning chime output.
THRTL SENSOR [deg]	×	×		<b>NOTE:</b> The item is displayed, but it is not monitored.
ENGINE RPM [rpm]	×			Indicates engine speed read from ADAS control unit through CAN communication (ECM transmits engine speed signal through CAN communication).
WIPER SW [OFF/LOW/HIGH]	×			Indicates wiper [OFF/LOW/HIGH] status (BCM transmits front wiper request signal through CAN communication).

# DIAGNOSIS SYSTEM (ADAS CONTROL UNIT)

< SYSTEM DESCRIPTION >

[ICC]

Monitored item [Unit]	ALL SIG (ICC)	MAIN SIG (ICC)	MAIN SIG (BSW)	Description
YAW RATE [deg/s]	×			<b>NOTE:</b> The item is displayed, but it is not monitored.
BA WARNING [On/Off]	×			Indicates [ON/OFF] status of FEB indicator lamp output.
STP LMP DRIVE [On/Off]	×	×		Indicates [ON/OFF] status of ICC brake hold relay drive output.
D POSITION SW [On/Off]	×			Indicates [ON/OFF] status of "D" or "M" positions read from ADAS control unit through CAN communication; ON when position "D" or "M" (TCM transmits shift selector position signal through CAN communication).
NP RANGE SW [On/Off]	×			Indicates shift selector position signal read from ADAS control unit through CAN communication (TCM transmits shift selector position signal through CAN communication).
PKB SW [On/Off]	×			Parking brake switch status [ON/OFF] judged from the parking brake switch signal that ADAS control unit receives via CAN communication is displayed (combination meter transmits the parking brake switch signal via CAN communication).
PWR SUP MONI [V]	×	×		Indicates ignition voltage input monitored by ADAS control unit.
VHCL SPD AT [km/h] or [mph]	×			Indicates vehicle speed calculated from CVT vehicle speed sensor read from ADAS control unit through CAN communication (TCM transmits CVT vehicle speed sensor signal through CAN communication).
THRTL OPENING [%]	×	×		Indicates throttle position read from ADAS control unit through CAN communication (ECM transmits accelerator pedal position signal through CAN communication).
GEAR [1, 2, 3, 4, 5, 6, 7]	×			Indicates CVT gear position read from ADAS control unit through CAN communication (TCM transmits current gear position signal through CAN communication).
CLUTCH SW SIG [On/Off]	×	×	×	Indicates [ON/OFF] status as judged from clutch pedal position signal (ECM transmits ICC clutch switch signal through CAN communication).
NP SW SIG [On/Off]	×			Indicates [ON/OFF] status as judged from park/neutral position switch signal (ECM transmits park/neutral position switch signal through CAN communication).
MODE SIG [OFF, ICC, ASCD]	×			Indicates the active mode from ICC or ASCD [conventional (fixed speed) cruise control mode].
SET DISP IND [On/Off]	×			Indicates [ON/OFF] status of SET switch indicator output.
DISTANCE [m]	×			Indicates the distance from the vehicle ahead.
RELATIVE SPD [m/s]	×			Indicates the relative speed of the vehicle ahead.
ON ROOT GUIDANCE [On/Off]	×			<b>NOTE:</b> The item is displayed, but it is not monitored.
DYNA ASIST SW [On/Off]	×	×	×	Indicates [ON/OFF] status as judged from ICC steering switch signal (ECM transmits ICC steering switch signal through CAN communication).
IBA SW [On/Off]	×	×		<b>NOTE:</b> The item is displayed, but it is not monitored.
NAVI ICC DISP [On/Off]				<b>NOTE:</b> The item is displayed, but it is not monitored.
Shift position [Off, P, R, N, D, M/T1 - 7]			×	Indicates shift selector position read from ADAS control unit through CAN communication (TCM transmits shift selector position signal through CAN communication).

A  
B  
C  
D  
E  
F  
G  
H  
I  
J  
K  
L  
M  
N  
P

CCS

# DIAGNOSIS SYSTEM (ADAS CONTROL UNIT)

< SYSTEM DESCRIPTION >

[ICC]

Monitored item [Unit]	ALL SIG (ICC)	MAIN SIG (ICC)	MAIN SIG (BSW)	Description
Turn signal [OFF/LH/RH/LH&RH]			×	Indicates turn signal operation status read from ADAS control unit through CAN communication (BCM transmits turn indicator signal through CAN communication).
SIDE G [G]			×	Indicates lateral G acting on the vehicle. This lateral G is judged from a side G sensor signal read by ADAS control unit via CAN communication. (The ABS actuator and electric unit (control unit) transmits a side G sensor signal via CAN communication).
FUNC ITEM (FCW) [On/Off]	×	×	×	Indicates system which can be set to ON/OFF by selecting "Driver Assistance" ⇒ "Emergency Brake" of the integral switch: Forward Emergency Braking.
FUNC ITEM (BSW) [On/Off]	×	×	×	Indicates system which can be set to ON/OFF by selecting "Driver Assistance" ⇒ "Blind Spot" of the integral switch: Blind Spot Warning.
FUNC ITEM (NV-ICC) [Off]	×	×	×	<b>NOTE:</b> The item is displayed, but it is not monitored.
FCW SELECT [On/Off]	×	×	×	Indicates an ON/OFF state of the PFCW system. The PFCW system can be set to ON/OFF by selecting "Driver Assistance" ⇒ "Emergency Brake" of the integral switch.
BSW SELECT [On/Off]	×	×	×	Indicates an ON/OFF state of the BSW system. The BSW system can be set to ON/OFF by selecting "Driver Assistance" ⇒ "Blind Spot" of the integral switch.
NAVI ICC SELECT [Off]	×	×	×	<b>NOTE:</b> The item is displayed, but it is not monitored.
SYS SELECTABILITY [On/Off]	×	×	×	Indicates the availability of ON/OFF switching for "Driving Aids" items received from the integral switch via CAN communication.
BSW/BSI WARN LMP [On/Off]			×	Indicates [ON/OFF] status of Blind Spot Warning malfunction.
BSW SYSTEM ON [On/Off]			×	Indicates [ON/OFF] status of BSW system.
FCW SYSTEM ON [On/Off]	×	×		Indicates [ON/OFF] status of PFCW system.
BATTERY CIRCUIT OFF [On/Off]	×			<b>NOTE:</b> The item is displayed, but it is not used.
SYSTEM CANCEL MESSAGE [NOREQ/SLIP/VDC OFF]	×	×	×	Indicates [ON/OFF] status of system cancel display output.
BSW ON INDICATOR [On/Off]			×	Indicates [ON/OFF] status of BSW system ON display output.
SIDE RADAR BLOCK COND [On/Off]			×	Indicates [ON/OFF] status of side radar with dirt or foreign materials.
BSW IND BRIGHT- NESS [Nothing/Bright/Normal/ Dark]			×	Indicates status of brightness of Blind Spot Warning indicator.
SL MAIN SW [On/Off]		×		Indicates [ON/OFF] status as judged from steering switch.
FUNC ITEM(FEB) [On/Off]	×			Indicates system which can be set to ON/OFF by selecting "Driver Assistance" ⇒ "Emergency Brake" of the integral switch: Forward Emergency Braking

# DIAGNOSIS SYSTEM (ADAS CONTROL UNIT)

< SYSTEM DESCRIPTION >

[ICC]

Monitored item [Unit]	ALL SIG (ICC)	MAIN SIG (ICC)	MAIN SIG (BSW)	Description
FEB SELECT [On/Off]	×			Indicates an ON/OFF state of the FEB system. The FEB system can be set to ON/OFF by selecting "Driver Assistance"→"Emergency Brake" of the integral switch.
FEB SW [On/Off]	×			Indicates [ON/OFF] status of FEB system.
SL TARGET VEHICLE SPEED [km/h] or [mph]	×			Indicates set vehicle speed memorized in ADAS control unit.
SL SET LAMP [On/Off]	×			Indicates [ON/OFF] status of speed limiter SET display output.
SL LIMIT LAMP [On/Off]	×			Indicates [ON/OFF] status of speed limiter MAIN switch display output.
ASCD CANCEL (LOW SPEED) [NON/CUT]	×			Indicates the vehicle cruise condition. • NON: Vehicle speed is maintained at the ASCD set speed. • CUT: Vehicle speed decreased to excessively low, and ASCD operation is cut off.
ASCD CANCEL (SPEED DIFF) [NON/CUT]	×			Indicates the vehicle cruise condition. • NON: Vehicle speed is maintained at the ASCD set speed. • CUT: Vehicle speed decreased to excessively low compared with the ASCD set speed, and ASCD operation is cut off.
KICK DOWN [On/Off]	×			Displays Kick down state. • On: Accelerator pedal is depressed. • Off: Accelerator pedal is fully released.

## ACTIVE TEST

### CAUTION:

- **Never perform "Active Test" while driving the vehicle.**
- **The "Active Test" cannot be performed when the following systems malfunction is displayed.**
- ICC system
- Blind Spot Warning/RCTA
- PFCW/FEB
- **The "Active Test" cannot be performed when the FEB warning lamp is illuminated.**
- **The "Active Test" cannot be performed when the ICC System is ON.**

Test item	Description
METER LAMP	The FEB warning lamp can be illuminated by ON/OFF operation as necessary.
STOP LAMP	The ICC brake hold relay can be operated by ON/OFF operation as necessary, and the stop lamp can be illuminated.
METER BUZZER	Sounds a buzzer used for BSW, RCTA, ICC, PFCW and FEB by arbitrarily operating ON/OFF.
BRAKE ACTUATOR 1	Activates the brake by an arbitrary operation.
BRAKE ACTUATOR 2	
BRAKE ACTUATOR 3	

## METER LAMP

### NOTE:

The test can be performed only when the engine is running.

Test item	Operation	Description	FEB warning lamp
METER LAMP	Off	Stops sending the FEB warning lamp signal to exit from the test.	OFF
	On	Transmits the FEB warning lamp signal to the combination meter via CAN communication.	ON

## STOP LAMP

# DIAGNOSIS SYSTEM (ADAS CONTROL UNIT)

< SYSTEM DESCRIPTION >

[ICC]

Test item	Operation	Description	Stop lamp
STOP LAMP	Off	Stops transmitting the ICC brake hold relay drive signal to end the test.	OFF
	On	Transmits the ICC brake hold relay drive signal.	ON

## METER BUZZER

Test item	Operation	Description	Operation sound
METER BUZZER	Off	Stops buzzer output to the combination meter via CAN communication.	—
	On	Starts buzzer output to the combination meter via CAN communication.	—

## BRAKE ACTUATOR

**NOTE:**

The test can be performed only when the engine is running.

Test item	Operation	Description	"PRESS ORDER" value
BRAKE ACTUATOR 1	Off	Stops transmitting the brake fluid pressure control signal to end the test.	—
	On	Starts transmitting the brake fluid pressure control signal to start the test.	10 bar
BRAKE ACTUATOR 2	Off	Stops transmitting the brake fluid pressure control signal to end the test.	—
	On	Starts transmitting the brake fluid pressure control signal to start the test.	20 bar
BRAKE ACTUATOR 3	Off	Stops transmitting the brake fluid pressure control signal to end the test.	—
	On	Starts transmitting the brake fluid pressure control signal to start the test.	30 bar

**NOTE:**

The test is finished 10 seconds after starting.

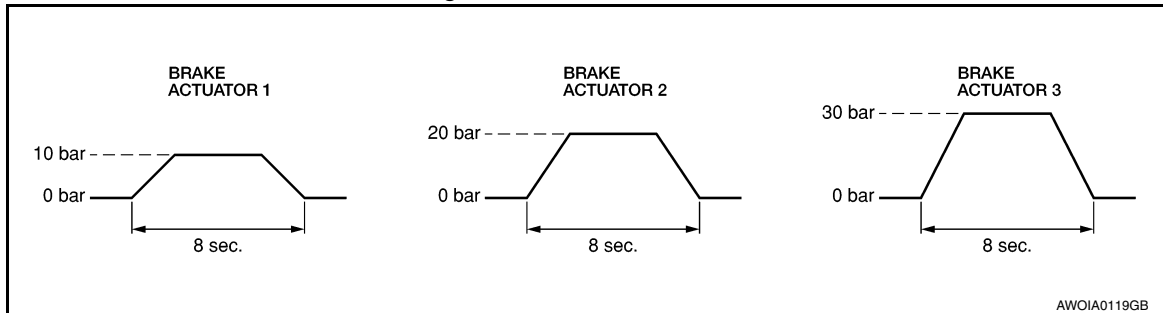

## ECU IDENTIFICATION

Displays ADAS control unit part number.

# DIAGNOSIS SYSTEM (ICC SENSOR)

< SYSTEM DESCRIPTION >

[ICC]

## DIAGNOSIS SYSTEM (ICC SENSOR)

### CONSULT Function (LASER/RADAR)

INFOID:0000000011952935

#### APPLICATION ITEMS

CONSULT performs the following functions via CAN communication with ADAS control unit and the communication with ICC sensor.

Diagnosis mode	Description
Self Diagnostic Result	Displays malfunctioning system memorized in ICC sensor
Data Monitor	Displays real-time input/output data of ICC sensor
Work support	It can monitor the adjustment direction indication in order to perform the radar adjustment operation smoothly
ECU Identification	Displays ICC sensor part number
CAN Diag Support Monitor	The results of transmit/receive diagnosis of ITS communication can be read.

#### SELF DIAGNOSTIC RESULT

Refer to [CCS-46, "DTC Index"](#).

#### DATA MONITOR

Monitored item [Unit]	Description
VHCL SPEED SE [km/h] or [mph]	Vehicle speed judged from a vehicle speed signal read by the ICC sensor via ITS communication is displayed [ADAS control unit receives a vehicle speed signal from ABS actuator and electric unit (control unit) via CAN communication and transmits the calculated vehicle speed to ICC sensor via ITS communication].
YAW RATE [deg/s]	Indicates yaw rate read from ADAS control unit through ITS communication [ADAS control unit receives yaw rate signal from ABS actuator and electric unit (control unit) via CAN communication and transmits yaw rate calculated by the ADAS control unit] Yaw rate judged from a yaw rate signal read by ICC sensor via ITS communication is displayed [ADAS control unit receives a yaw rate signal from ABS actuator and electric unit (control unit) via CAN communication and transmits the calculated yaw rate to ICC sensor via ITS communication].
PWR SUP MONI [V]	Indicates IGN voltage input by ICC sensor
DISTANCE [m]	Indicates the distance from the vehicle ahead
RELATIVE SPD [m/s]	Indicates the relative speed of the vehicle ahead
LASER OFFSET [m]	<b>NOTE:</b> The item is indicated but not used.
LASER HEIGHT [m]	<b>NOTE:</b> The item is indicated but not used.
STEERING ANGLE [deg]	The steering angle is displayed.
STRG ANGLE SPEED [deg/s]	The steering angle speed is displayed.
L/R ADJUST [deg]	Indicates a horizontal correction value of the radar
U/D ADJUST [deg]	Indicates a vertical correction value of the radar
FCW SYSTEM ON	<b>NOTE:</b> The item is indicated, but not used.
FCW SELECT	<b>NOTE:</b> The item is indicated, but not used.

## DIAGNOSIS SYSTEM (ICC SENSOR)

< SYSTEM DESCRIPTION >

[ICC]

Monitored item [Unit]	Description
PFCW SELECT	NOTE: The item is indicated, but not used.
PFCW SYSTEM ON	NOTE: The item is indicated, but not used.
FEB SW	NOTE: The item is indicated, but not used.
FEB SELECT	Indicates [ON/OFF] state of the PFCW system.
MAIN SW	Indicates [ON/OFF] status as judged from ICC steering switch.
ICC/ASCD MODE	NOTE: The item is indicated, but not used.
SET/COAST SW	Indicates [ON/OFF] status as judged from ICC steering switch.
CANCEL SW	Indicates [ON/OFF] status as judged from ICC steering switch.
RESUME/ACC SW	Indicates [ON/OFF] status as judged from ICC steering switch.
DISTANCE SW	Indicates [ON/OFF] status as judged from ICC steering switch.
BRAKE SW	Indicates [ON/OFF] status as judged from brake pedal position switch signal [ECM transmits brake pedal position switch signal through CAN communication].
STOP LAMP SW	Indicates [ON/OFF] status as judged from stop lamp switch signal [ABS actuator and electric unit (control unit) transmits stop lamp switch signal through CAN communication].
IDLE SW	Indicates [ON/OFF] status of idle switch read from ICC sensor through CAN communication (ECM transmits ON/OFF status through CAN communication).
CRUISE LAMP	Indicates [ON/OFF] status of MAIN switch indicator output.
OWN VHCL	NOTE: The item is indicated, but not used.
VHCL AHEAD	Indicates [ON/OFF] status of vehicle ahead detection indicator output.
SET DISTANCE	Indicates set distance memorized in ADAS control unit.
SET VHCL SPD [km/h] or [mph]	NOTE: The item is indicated, but not used.
THRTL SENSOR [%]	Indicates throttle position read from ISS sensor through CAN communication (ECM transmits accelerator pedal position signal through CAN communication).
VEHICLE AHEAD DETECT	Indicates [ON/OFF] status of vehicle ahead detection indicator output.
STATIC OBSTACLE DETECT	Indicates [ON/OFF] status of static obstacle detection.
BUZZER O/P	[ON/OFF] Indicates [On/Off] status of warning chime output.
FUNC ITEM (FCW)	NOTE: The item is indicated, but not used.
FUNC ITEM (PFCW)	Indicates systems status
FUNC ITEM (FEB)	Indicates systems status
FUNC ITEM (ICC)	Indicates systems status
PRESS_ORDER [bar]	Indicates status as judged from brake fluid pressure signal [ABS actuator and electric unit (control unit) transmits brake fluid pressure signal through CAN communication].
D RANGE SW	Indicates [ON/OFF] status as judged from D position switch signal (TCM transmits shift position signal through CAN communication).
NP RANGE SW	Indicates [ON/OFF] status as judged from N/P position switch signal (TCM transmits shift position signal through CAN communication).
PKB SW	Parking brake switch status [ON/OFF] judges from the parking brake switch signal that ADAS control unit readout via CAN communication is displayed (combination meter transmits the parking brake switch signal via CAN communication)
VHCL SPD AT	NOTE: The item is indicated, but not used.



# DIAGNOSIS SYSTEM (ICC SENSOR)

< SYSTEM DESCRIPTION >

[ICC]

Monitored item [Unit]	Description
Shift position	Indicates shift position read from ADAS control unit though CAN communication (TCM transmits shift position signal through CAN communication).
Turn signal	NOTE: The item is indicated, but not used.
SYSTEM CANCEL MESSAGE	Indicates [ON/OFF] status of system cancel display output.
DISP VHCL SPD [km/h] or [mph]	NOTE: The item is indicated, but not used.
VHCL SPD UNIT	Indicates vehicle speed unit read from ICC sensor through CAN communication (combination meter transmits vehicle speed unit through CAN communications).
ADAS AVAILABLE COND	NOTE: The item is indicated, but not used.
ICC SET STATUS	NOTE: The item is indicated, but not used.
ICC MALF	NOTE: The item is indicated, but not used.
ADAS MALF	Indicates [ON/OFF] status of ADAS malfunction.
STOP LAMP RELAY ON	Indicates [ON/OFF] status of stop lamp relay fixed on.
STOP LAMP RELAY OFF	Indicates [ON/OFF] status of stop lamp relay fixed off.
ACCEL COM VALUE 1 [m/s <sup>2</sup> ]	Indicates accel command calculated from set speed and information of ahead vehicle.
ICC STATUS	Indicates ICC status.
ACCEL COM VALUE 2	NOTE: The item is indicated, but not used.
MILEAGE	NOTE: The item is indicated, but not used.

## WORK SUPPORT

Work support items	Description
MILLIWAVE RADAR ADJUST	Outputs millimeter waves, calculates the displacement in radar direction, and indicates an adjustment direction
CAUSE OF AUTO-CANCEL	Displays causes of automatic cancellation occurred during Intelligent Cruise Control system.

ICC sensor Adjust

Refer to [CCS-59. "Description"](#).

## ECU IDENTIFICATION

ICC sensor part number is displayed.

## CAUSE OF AUTO CANCEL

Work support items	Description
OPERATING ABS	ABS function was operated.
OPERATING TCS	TCS function was operated.
OPERATING VDC	VDC function was operated.
ECM CIRCUIT	ECM did not permit ICC operation.
OP SW VOLT CIRC	The ICC steering switch input voltage is not within standard range.
OP SW DOUBLE TOUCH	The ICC steering switches were pressed at the same time.
VHCL SPD DOWN	Vehicle speed is lower than 24 km/h (15 mph).
WHL SPD ELEC NOISE	Wheel speed sensor signal caught electromagnetic noise.
VDC/TCS OFF SW	VDC OFF switch was pressed.

## DIAGNOSIS SYSTEM (ICC SENSOR)

[ICC]

### < SYSTEM DESCRIPTION >

Work support items	Description
VHCL SPD UNMATCH	Wheel speed became different from A/T vehicle speed.
TIRE SLIP	Wheel slipped.
IGN LOW VOLT	Decrease in ICC sensor ignition voltage.
PARKING BRAKE ON	The parking brake is operating.
WHEEL SPD UNMATCH	The wheel speed of all four wheels are out of the specified values.
INCHING LOST	a vehicle ahead is not detected during the following driving when the vehicle speed is approximately 24 km/h (15mph) or less.
CAN COMM ERROR	ICC sensor received an abnormal signal with CAN communication.
ABS/TCS/VDC CIRC	An abnormal condition occurs in VDC/TCS/ABS system.
ECD CIRCUIT	An abnormal condition occurs in ECD system.
ASCD VHCL SPD DTAC	Vehicle speed is detached from the set vehicle speed.
ASCD DOUBLE COMD	Cancel switch and operation switch are detected simultaneously.
FEB OPERATED	FEB activated.
VHL AHAD LOST (CLSE RANGE)	A vehicle ahead lost close range.
NO RECORD	—

# ADAS CONTROL UNIT

< ECU DIAGNOSIS INFORMATION >

[ICC]

## ECU DIAGNOSIS INFORMATION

### ADAS CONTROL UNIT

#### Reference Value

INFOID:0000000011952936

#### VALUES ON THE DIAGNOSIS TOOL

**NOTE:**

The following table includes information (items) inapplicable to this vehicle. For information (items) applicable to this vehicle, refer to CONSULT display items.

Monitor item	Condition		Value/Status
MAIN SW	Ignition switch ON	When MAIN (ON/OFF) switch is pressed.	On
		When MAIN (ON/OFF) switch is not pressed.	Off
SET/COAST SW	Ignition switch ON	When SET/COAST switch is pressed.	On
		When SET/COAST switch is not pressed.	Off
CANCEL SW	Ignition switch ON	When CANCEL switch is pressed.	On
		When CANCEL switch is not pressed.	Off
RESUME/ACC SW	Ignition switch ON	When RESUME/ACCELERATE switch is pressed.	On
		When RESUME/ACCELERATE switch is not pressed.	Off
DISTANCE SW	Ignition switch ON	When DISTANCE switch is pressed.	On
		When DISTANCE switch is not pressed.	Off
CRUISE OPE	Drive the vehicle and activate the ICC system	When ICC system is controlling.	On
		When ICC system is not controlling.	Off
BRAKE SW	Ignition switch ON	When brake or clutch pedal is depressed.	Off
		When brake or clutch pedal is not depressed.	On
STOP LAMP SW	Ignition switch ON	When brake pedal is depressed.	On
		When brake pedal is not depressed.	Off
IDLE SW	Engine running	Idling	On
		Except idling (depress accelerator pedal)	Off
SET DISTANCE	<ul style="list-style-type: none"> <li>• Start the engine and turn the ICC system ON</li> <li>• Press the DISTANCE switch to change the ICC system</li> </ul>	When set to "long"	Long
		When set to "middle"	Mid
		When set to "short"	Short
CRUISE LAMP	Start the engine and press MAIN switch	ICC system ON (MAIN switch indicator ON).	On
		ICC system OFF (MAIN switch indicator OFF).	Off
OWN VHCL	<b>NOTE:</b> The item is indicated, but not monitored		Off
VHCL AHEAD	Drive the vehicle and activate the ICC system	When a vehicle ahead is detected (vehicle ahead detection indicator ON).	On
		When a vehicle ahead is not detected (vehicle ahead detection indicator OFF).	Off
ICC WARNING	Start the engine and press MAIN switch	When ICC system is malfunctioning (ICC system malfunction ON).	On
		When ICC system is normal (ICC system malfunction OFF).	Off

A  
B  
C  
D  
E  
F  
G  
H  
I  
J  
K  
L  
M  
N  
P

CCS

# ADAS CONTROL UNIT

< ECU DIAGNOSIS INFORMATION >

[ICC]

Monitor item	Condition		Value/Status
VHCL SPEED SE	While driving		Displays the vehicle speed calculated by ADAS control unit
SET VHCL SPD	While driving	When vehicle speed is set.	Displays the set vehicle speed
BUZZER O/P	Engine running	When the buzzer of the following system operates: • ICC system • PFCW system • FEB system	On
		When the buzzer of the following system does not operate: • ICC system • PFCW system • FEB system	Off
THRTL SENSOR	<b>NOTE:</b> The item is indicated, but not monitored.		0.0
ENGINE RPM	Engine running		Equivalent to tachometer reading
WIPER SW	Ignition switch ON	Wiper not operating.	Off
		Wiper LO operation.	Low
		Wiper HI operation.	High
YAW RATE	<b>NOTE:</b> The item is indicated, but not monitored.		0.0
BA WARNING	Engine running	FEB OFF indicator lamp ON. • When FEB system is malfunctioning. • When FEB system is turned to OFF.	On
		FEB OFF indicator lamp OFF. • When FEB system is normal. • When FEB system is turned to ON.	Off
STP LMP DRIVE	Drive the vehicle and activate the ICC system	When ICC brake hold relay is activated.	On
		When ICC brake hold relay is not activated.	Off
D POSITION SW	Engine running	When the shift selector is in "D" position or manual mode.	On
		When the shift selector is in any position other than "D" or manual mode.	Off
NP RANGE SW	Engine running	When the shift selector is in "N" or "P" position.	On
		When the shift selector is in any position other than "N" or "P".	Off
PKB SW	Ignition switch ON	When the parking brake is applied.	On
		When the parking brake is released.	Off
PWR SUP MONI	Engine running		Power supply voltage value of ADAS control unit
VHCL SPD AT	While driving		Value of CVT vehicle speed sensor signal
THRTL OPENING	Engine running	Depress accelerator pedal.	Displays the throttle position
GEAR	While driving		Displays the gear position

# ADAS CONTROL UNIT

< ECU DIAGNOSIS INFORMATION >

[ICC]

Monitor item	Condition		Value/Status
CLUTCH SW SIG	Ignition switch ON	When clutch or brake pedal is depressed.	On
		When clutch or brake pedal is not depressed.	Off
NP SW SIG	Ignition switch ON	When the shift selector is in neutral position.	On
		When the shift selector is in any position other than neutral.	Off
MODE SIG	Start the engine and press MAIN switch	When ICC system is deactivated.	Off
		When ICC system is activated.	ICC
SET DISP IND	Press SET/COAST switch	SET switch indicator ON.	On
		SET switch indicator OFF.	Off
DISTANCE	Drive the vehicle and activate the ICC system	When a vehicle ahead is detected.	Displays the distance from the preceding vehicle
		When a vehicle ahead is not detected.	0.0
RELATIVE SPD	Drive the vehicle and activate the ICC system	When a vehicle ahead is detected.	Displays the relative speed.
		When a vehicle ahead is not detected.	0.0
ON ROOT GUIDE	<b>NOTE:</b> The item is indicated, but not monitored.		Off
FCW SYSTEM ON	Ignition switch ON	When the PFCW system is ON.	On
		When the PFCW system is OFF.	Off
Shift position	<ul style="list-style-type: none"> <li>• Engine running</li> <li>• While driving</li> </ul>		Displays the shift selector position
Turn signal	Turn signal lamps OFF.		Off
	Turn signal lamp LH blinking.		LH
	Turn signal lamp RH blinking.		RH
	Turn signal lamp LH and RH blinking.		LH&RH
SIDE G	While driving	Vehicle turning right.	Negative value
		Vehicle turning left.	Positive value
FUNC ITEM	Ignition switch ON		FUNC3
FUNC ITEM (FCW)	Engine running		On
FUNC ITEM (BSW)	Engine running		On
FUNC ITEM (NV-ICC)	<b>NOTE:</b> The item is indicated, but not monitored		Off
FCW SELECT	Ignition switch ON	"Forward Emergency Braking" set when the integral switch is ON.	On
		"Forward Emergency Braking" set when the integral switch is OFF.	Off
BSW SELECT	Ignition switch ON	"Blind Spot Warning" set when the integral switch is ON.	On
		"Blind Spot Warning" set when the integral switch is OFF.	Off
NAVI ICC SELECT	<b>NOTE:</b> The item is indicated, but not monitored.		Off
SYS SELECTABILITY	Ignition switch ON	Items set with the integral switch can be switched normally.	On
		Items set with the integral switch cannot be switched normally.	Off

A  
B  
C  
D  
E  
F  
G  
H  
I  
J  
K  
L  
M  
N  
P

CCS

# ADAS CONTROL UNIT

< ECU DIAGNOSIS INFORMATION >

[ICC]

Monitor item	Condition		Value/Status
BSW WARN LMP	Engine running	When the BSW system is malfunctioning.	On
		When the BSW system is normal.	Off
BSW SYSTEM ON	Ignition switch ON	When the BSW system is ON.	On
		When the BSW system is OFF.	Off
FCW SYSTEM ON	Engine running	When the FEB/PFCW system is ON.	On
		When the FEB/PFCW system is OFF.	Off
BATTERY CIRCUIT OFF	<b>NOTE:</b> The item is indicated, but not used.		Off
SYSTEM CANCEL MESSAGE	Engine running	System cancel display ON.	On
		System cancel display OFF.	Off
BSW ON INDICATOR	Engine running	BSW system display ON.	On
		BSW system display OFF.	Off
SIDE RADAR BLOCK COND	Engine running	Front bumper or side radar is dirty.	On
		Front bumper and side radar are clean.	Off
BSW IND BRIGHTNESS	Ignition switch ON	BSW system OFF.	Nothing
		Blind Spot Warning indicator brightness bright.	Bright
		Blind Spot Warning indicator brightness normal.	Normal
		Blind Spot Warning indicator brightness dark.	Dark
SL MAIN SW	Engine running	When speed limiter MAIN switch is pressed.	On
		When speed limiter MAIN switch is not pressed.	Off
FUNC ITEM (FEB)	Engine running		On
FEB SELECT	Ignition switch ON	"Forward Emergency Braking" set when the integral switch is ON.	On
		"Forward Emergency Braking" set when the integral switch is OFF.	Off
FEB SW	Engine running	FEB system ON.	On
		FEB system OFF.	Off
SL TARGET VEHICLE SPEED	While driving	When vehicle speed is set.	Displays the set vehicle speed
SL SET LAMP	<ul style="list-style-type: none"> <li>• Drive the vehicle and activate the speed limiter</li> <li>• Press speed limiter MAIN switch</li> </ul>	Speed limiter SET indicator ON.	On
		Speed limiter SET indicator OFF.	Off
SL LIMIT LAMP	<ul style="list-style-type: none"> <li>• Drive the vehicle and activate the speed limiter</li> <li>• Press speed limiter MAIN switch</li> </ul>	Speed limiter system ON.	On
		Speed limiter system OFF.	Off
ASCDCANCEL (LOW SPEED)	Drive the vehicle and activate the ASCD	ASCDCancelled by low vehicle speed.	On
		Other than above.	Off
ASCDCANCEL (SPEED DIFF)	Drive the vehicle and activate the ASCD	ASCDCancelled by difference between set speed and vehicle speed.	On
		Other than above.	Off
KICK DOWN	Drive the vehicle and activate the speed limiter	When accelerator pedal is fully depressed.	On
		Other than above.	Off

# ADAS CONTROL UNIT

< ECU DIAGNOSIS INFORMATION >

[ICC]

TERMINAL LAYOUT

PHYSICAL VALUES

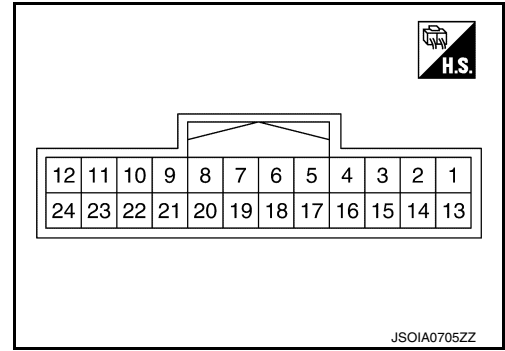

Terminal No. (Wire color)		Description		Condition		Value (Approx.)
+	-	Signal name	Input/ Output			
1 (B)	Ground	Ground	Input	—		0 V
2 (L)		ITS communication high	—	—		—
3 (BG)		Ignition power supply	Input	Ignition switch ON		Battery voltage
5 (Y)		ITS communication low	—	—		—
9 (L)		CAN high	—	—		—
10 (P)		CAN low	—	—		—
14 (W)		ICC brake hold relay drive signal	Output	Ignition switch ON	—	

## Fail-safe (ADAS Control Unit)

INFOID:0000000011952937

If a malfunction occurs in each system, ADAS control unit cancels each control, sounds a beep, and turns ON the warning or indicator lamp.

System	Buzzer	Warning lamp/Warning display	Description
Intelligent Cruise Control (ICC)	High-pitched tone	ICC system warning	Cancel
Forward Emergency Braking (FEB)	High-pitched tone	FEB warning lamp (Yellow)	Cancel
Predictive Forward Collision Warning (PFCW)	High-pitched tone	FEB warning lamp (Yellow)	Cancel
Blind Spot Warning (BSW)	Low-pitched tone	BSW system warning	Cancel
Rear Cross Traffic Alert (RCTA)	—	BSW system warning	Cancel

## DTC Inspection Priority Chart

INFOID:0000000011952938

If multiple DTCs are detected simultaneously, check them one by one depending on the following DTC inspection priority chart.

A  
B  
C  
D  
E  
F  
G  
H  
I  
J  
K  
L  
M  
N  
P

CCS

# ADAS CONTROL UNIT

< ECU DIAGNOSIS INFORMATION >

[ICC]

Priority	Detected items (DTC)
1	<ul style="list-style-type: none"> <li>• U1507: LOST COMM (SIDE RDR R)</li> <li>• U1508: LOST COMM (SIDE RDR L)</li> </ul>
2	<ul style="list-style-type: none"> <li>• U1000: CAN COMM CIRCUIT</li> <li>• U1321: CONFIGURATION</li> </ul>
3	<ul style="list-style-type: none"> <li>• C1A17: ICC SENSOR MALF</li> <li>• C1B53: SIDE RDR R MALF</li> <li>• C1B54: SIDE RDR L MALF</li> </ul>
4	<ul style="list-style-type: none"> <li>• C1A01: POWER SUPPLY CIR</li> <li>• C1A02: POWER SUPPLY CIR 2</li> <li>• C1A13: STOP LAMP RLY FIX</li> <li>• C1A14: ECM CIRCUIT</li> <li>• C1A34: COMMAND ERROR</li> <li>• U0121: VDC CAN CIR 2</li> <li>• U0235: ICC SENSOR CAN CIRC 1</li> <li>• U0401: ECM CAN CIR 1</li> <li>• U0402: TCM CAN CIR 1</li> <li>• U0415: VDC CAN CIR 1</li> <li>• U0433: ICC SENSOR CAN CIRC 2</li> <li>• U1503: SIDE RDR L CAN CIR 2</li> <li>• U1504: SIDE RDR L CAN CIR 1</li> <li>• U1505: SIDE RDR R CAN CIR 2</li> <li>• U1506: SIDE RDR R CAN CIR 1</li> </ul>
5	<ul style="list-style-type: none"> <li>• C1A03: VHCL SPEED SE CIRC</li> </ul>
6	<ul style="list-style-type: none"> <li>• C1A00: CONTROL UNIT</li> </ul>

## DTC Index

INFOID:000000011952939

### Systems for fail-safe

- A: Intelligent Cruise Control (ICC)
- B: Forward Emergency Braking (FEB)
- C: Predictive Forward Collision Warning (PFCW)
- D: Blind Spot Warning (BSW)
- E: Rear Cross Traffic Alert (RCTA)

DTC	CONSULT display	Fail-safe System	Reference
CONSULT			
NO DTC IS DETECTED. FURTHER TESTING MAY BE REQUIRED	NO DTC IS DETECTED. FURTHER TESTING MAY BE REQUIRED	—	—
U1507	LOST COMM (SIDE RDR R)	D, E	<a href="#">DAS-76</a>
U1508	LOST COMM (SIDE RDR L)	D, E	<a href="#">DAS-77</a>
U1000 <sup>NOTE</sup>	CAN COMM CIRCUIT	A, B, C, D, E	<a href="#">DAS-65</a>
U1321	CONFIGURATION	A, B, C, D, E	<a href="#">DAS-67</a>
C1A17	ICC SENSOR MALF	A, B, C	<a href="#">DAS-51</a>
C1B53	SIDE RDR R MALF	D, E	<a href="#">DAS-53</a>
C1B54	SIDE RDR L MALF	D, E	<a href="#">DAS-54</a>
C1A01	POWER SUPPLY CIR	A, B, C, D, E	<a href="#">DAS-40</a>
C1A02	POWER SUPPLY CIR 2	A, B, C, D, E	<a href="#">DAS-40</a>
C1A13	STOP LAMP RLY FIX	A, B, C	<a href="#">DAS-43</a>
C1A14	ECM CIRCUIT	A, B, C	<a href="#">DAS-49</a>
C1A34	COMMAND ERROR	A, B, C	<a href="#">DAS-52</a>
U0121	VDC CAN CIR 2	A, B, C, D, E	<a href="#">DAS-55</a>



# ADAS CONTROL UNIT

< ECU DIAGNOSIS INFORMATION >

[ICC]

Systems for fail-safe

- A: Intelligent Cruise Control (ICC)
- B: Forward Emergency Braking (FEB)
- C: Predictive Forward Collision Warning (PFCW)
- D: Blind Spot Warning (BSW)
- E: Rear Cross Traffic Alert (RCTA)

A  
B  
C  
D  
E  
F  
G  
H  
I  
J  
K  
L  
M  
N  
P

DTC	CONSULT display	Fail-safe System	Reference
U0235	ICC SENSOR CAN CIRC 1	A, C, D, E	<a href="#">DAS-57</a>
U0401	ECM CAN CIR 1	A, B, C, D, E	<a href="#">DAS-58</a>
U0402	TCM CAN CIR 1	A, B, C, D, E	<a href="#">DAS-60</a>
U0415	VDC CAN CIR 1	A, B, C, D, E	<a href="#">DAS-62</a>
U0433	ICC SENSOR CAN CIRC 2	A, B, C	<a href="#">DAS-64</a>
U1503	SIDE RDR L CAN CIR 2	D, E	<a href="#">DAS-68</a>
U1504	SIDE RDR L CAN CIR 1	D, E	<a href="#">DAS-70</a>
U1505	SIDE RDR R CAN CIR 2	D, E	<a href="#">DAS-72</a>
U1506	SIDE RDR R CAN CIR 1	D, E	<a href="#">DAS-74</a>
C1A03	VHCL SPEED SE CIRC	D, E	<a href="#">DAS-41</a>
C1A00	CONTROL UNIT	A, B, C, D, E	<a href="#">DAS-39</a>

**NOTE:**

With the detection of “U1000” some systems do not perform the fail-safe operation.  
 A system controlling based on a signal received from the control unit performs fail-safe operation when the communication with the ADAS control unit becomes inoperable.



# ICC SENSOR

< ECU DIAGNOSIS INFORMATION >

[ICC]

## ICC SENSOR

### Reference Value

INFOID:000000011952940

### VALUES ON THE DIAGNOSIS TOOL

Monitor item	Condition		Value/Status
VHCL SPEED SE	While driving		Value of vehicle speed signal (wheel speed)
YAW RATE	While driving	Vehicle stopped	0.0
		Vehicle turning right	Positive value
		Vehicle turning left	Negative value
PWR SUP MONI	Ignition switch ON		Power supply voltage value of ICC sensor
DISTANCE	Drive the vehicle and activate the ICC system.	When a vehicle ahead is detected	Displays the distance from the preceding vehicle
		When a vehicle ahead is not detected	0.0
RELATIVE SPD	Drive the vehicle and activate the ICC system.	When a vehicle ahead is detected	Displays the relative speed
		When a vehicle ahead is not detected	0.0
LASER OFFSET	<b>NOTE:</b> The item is indicated but not used.		—
LASER HEIGHT	<b>NOTE:</b> The item is indicated but not used.		—
STEERING ANGLE	Ignition switch ON	When setting the steering wheel in straight-ahead position	0.0
		When turning the steering wheel 90° rightward	+90
		When turning the steering wheel 90° leftward	-90
STRG ANGLE SPEED	Ignition switch ON	At the time of turning the steering wheel	Steering wheel turning speed is displayed
L/R ADJUST	Ignition switch ON	At the completion of radar alignment adjustment	Horizontal correction value is displayed
U/D ADJUST	Ignition switch ON	At the completion of radar alignment adjustment	Vertical correction value is displayed
FCW SYSTEM ON	<b>NOTE:</b> The item is indicated, but not used	—	OFF
FCW SELECT	<b>NOTE:</b> The item is indicated, but not used		—
PFCW SYSTEM ON	<b>NOTE:</b> The item is indicated, but not used		OFF
PFCW SELECT	Engine running	PFCW system set with the information display is ON	ON
		PFCW system set with the information display is OFF	OFF
FEB SW	<b>NOTE:</b> The item is indicated, but not used	—	—
FEB SELECT	Engine running	PFCW system set with the information display is ON	ON
		PFCW system set with the information display is OFF	OFF

# ICC SENSOR

< ECU DIAGNOSIS INFORMATION >

[ICC]

Monitor item	Condition		Value/Status
MAIN SW	Ignition switch ON	When MAIN switch is pressed	On
		When MAIN switch is not pressed	Off
ICC/ASCD MODE	Engine running	Intelligent Cruise Control System MAIN switch status	On
			Off
SET/COAST SW	Ignition switch ON	When SET/COAST switch is pressed	On
		When SET/COAST switch is not pressed	Off
CANCEL SW	Ignition switch ON	When CANCEL switch is pressed	On
		When CANCEL switch is not pressed	Off
RESUME/ACC SW	Ignition switch ON	When RESUME/ACC SW switch is pressed	On
		When RESUME/ACC SW switch is not pressed	Off
DISTANCE SW	Ignition switch ON	When DISTANCE switch is pressed	On
		When DISTANCE switch is not pressed	Off
BRAKE SW	Ignition switch ON	When brake pedal is depressed	On
		When brake pedal is not depressed	Off
STOP LAMP SW	Ignition switch ON	When brake pedal is depressed	On
		When brake pedal is not depressed	Off
IDLE SW	Engine running	Idling	On
		Except idling (depress accelerator pedal)	Off
CRUISE LAMP	Start the engine and press MAIN switch	ICC system ON (MAIN switch indicator ON)	On
		ICC system OFF (MAIN switch indicator OFF)	Off
OWN VHCL	NOTE: The item is indicated, but not used.	—	Off
VHCL AHEAD	Drive the vehicle and activate the Intelligent Cruise Control System	When a vehicle ahead is detected (vehicle ahead detection indicator ON)	On
		When a vehicle ahead is detected (vehicle ahead detection indicator OFF)	Off
SET DISTANCE	<ul style="list-style-type: none"> <li>• Start the engine and turn the ICC system ON</li> <li>• Press the DISTANCE switch to change the distance setting</li> </ul>	When set to "long"	LONG
		When set to "middle"	MID
		When set to "short"	SHORT
SET VHCL SPD	NOTE: The item is indicated, but not used.	—	—
THRT SENSOR [%]	Engine running	Depress accelerator pedal	Displays the throttle position
VEHICLE AHEAD DETECT	Engine running		—
STATIC OBSTACLE DETECT	Indicates [ON/Off] status of static obstacle detection		—
BUZZER O/P	Engine running	When the buzzer of the following system operates: <ul style="list-style-type: none"> <li>• Intelligent Cruise Control System</li> <li>• PFCW system</li> <li>• FEB system</li> </ul>	On
		When the buzzer of the following system does not operate: <ul style="list-style-type: none"> <li>• Intelligent Cruise Control System</li> <li>• PFCW system</li> <li>• FEB system</li> </ul>	Off

A  
B  
C  
D  
E  
F  
G  
H  
I  
J  
K  
L  
M  
N  
P

CCS

# ICC SENSOR

< ECU DIAGNOSIS INFORMATION >

[ICC]

Monitor item	Condition		Value/Status
FUNC ITEM (FCW)	Ignition switch ON	—	—
FUNC ITEM (PFCW)			On
FUNC ITEM (FEB)			
FUNC ITEM (ICC)			
PRESS_ORDER	Engine running	—	
D RANGE SW	Engine running	When the selector lever is in "D" position or manual mode	On
		When the selector lever is in any other than "D" or manual mode	Off
NP RANGE SW	Engine running	When the selector lever is in "N""P"	On
		When the selector lever is in any other than "N""P"	Off
PKB SW	Ignition switch ON	When the parking brake is applied	On
		When the parking brake is released	Off
VHCL SPD AT	While driving	—	Value of A/T vehicle speed sensor signal
Shift position	<ul style="list-style-type: none"> <li>• Engine running</li> <li>• While driving</li> </ul>	—	Displays the shift position
Turn signal	NOTE: The item is indicated, but not used	—	Off
SYSTEM CANCEL MESSAGE	Engine running	System cancel display OFF	NO REQ
		System cancel reason is slippery road	SLIP
		System cancel reason is VDC OFF	VDC OFF
DISP VHCL SPD UNIT			
VHCL SPD UNIT	Engine running	Meter indicates km/h	km/h
		Meter indicates mph	mph
ADAS AVAILABLE COND	NOTE: The item is indicated, but not used	—	—
ICC SET STATUS			
ICC MALF			
ADAS MALF	Engine running	ADAS is malfunction	On
		ADAS is not malfunction	Off
STOP LAMP RELAY ON	Engine running	Stop lamp relay is fixed on	On
		Stop lamp relay is not fixed on	Off
STOP LAMP RELAY OFF	Engine running	Stop lamp relay is fixed off	On
		Stop lamp relay is not fixed off	Off
ICC CANCEL	NOTE: The item is indicated, but not used	—	—
ACCEL COM VALUE 1 [m/s <sup>2</sup> ]	Engine running	—	ICC sensor request accel command to ADAS controller
ICC STATUS	Engine running	Intelligent Cruise Control System Off	Off
		Intelligent Cruise Control System On	ICC
		Intelligent Cruise Control System On and vehicle is stopped	STOP1
		Intelligent Cruise Control System On and Driver depressed accelerator pedal	ACCEL

# ICC SENSOR

< ECU DIAGNOSIS INFORMATION >

[ICC]

Monitor item	Condition	Value/Status
ACCCEL COM VALUE 2	NOTE: The item is indicated, but not used	—
MILEAGE		

## TERMINAL LAYOUT

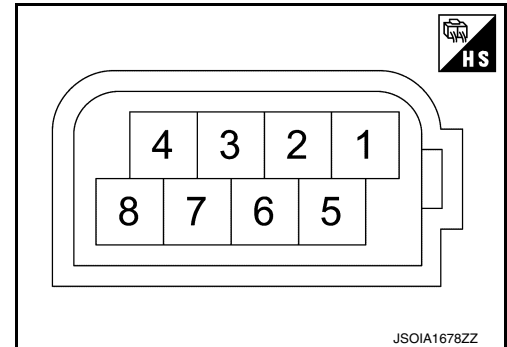

## PHYSICAL VALUES

Terminal No. (Wire color)		Description		Condition	Standard value	Reference value (Approx.)
+	-	Signal name	Input/ Output			
1 (GR)	—	Ground	—	Ignition switch ON	0 - 0.1 V	0 V
2 (L)	—	ITS communication-H	—	—	—	—
3 (Y)		ITS communication-L	—	—	—	—
8 (BG)	—	Ignition power supply	Input	Ignition switch ON	9.5 - 16 V	Battery voltage

## Fail-safe

INFOID:000000011952941

If a malfunction occurs in the ICC sensor, ADAS control unit cancels control, sounds a beep, and turns ON the ICC system warning lamp in the combination meter.

## DTC Inspection Priority Chart

INFOID:000000011952942

If multiple DTCs are detected simultaneously, check them one by one depending on the following DTC inspection priority chart.

Priority	Detected items (DTC)
1	<ul style="list-style-type: none"> <li>U1000: CAN COMM CIRCUIT</li> <li>U1010: CONTROL UNIT (CAN)</li> </ul>
2	<ul style="list-style-type: none"> <li>C1A50: ADAS MALFUNCTION</li> <li>C1A0C: ADAS MSG COUNTER</li> <li>C1A0C: ADAS CRC ERROR</li> </ul>

CCS

# ICC SENSOR

< ECU DIAGNOSIS INFORMATION >

[ICC]

Priority	Detected items (DTC)
3	<ul style="list-style-type: none"> <li>• C1A01: POWER SUPPLY CIR</li> <li>• C1A02: POWER SUPPLY CIR 2</li> <li>• C1A04: ABS/TCS/VDC CIRC</li> <li>• C1A05: BRAKE SW/STOP L SW</li> <li>• C1A06: OPERATION SW CIRC</li> <li>• C1A07: CVT CIRCUIT</li> <li>• C1A12: LASER BEAM OFFCNTR</li> <li>• C1A13: STOP_LAMP_RLY_FIX</li> <li>• C1A14: ECM_CIRCUIT</li> <li>• C1A16: RADAR STAIN</li> <li>• C1A18: LASER AIMING INCOMP</li> <li>• C1A21: UNIT HIGH TEMP</li> <li>• C1A24: NP RANGE</li> <li>• C1A26: ECD MODE MALF</li> <li>• C1A27: ECD POWER SUPPLY CIRC</li> <li>• C1A39: STRG SEN CIR</li> <li>• C1B5D: FEB OPE COUNT LIMIT</li> <li>• C10B7: YAW RATE SENSOR</li> <li>• U0121: VDC CAN CIR2</li> <li>• U153A: TCM CAN CIR 1</li> <li>• U153B: TCM CAN CIR 2</li> <li>• U153D: ECM CAN CIR 2</li> <li>• U0126: STRG SEN CAN CIR1</li> <li>• U0401: ECM CAN CIR 1</li> <li>• U0415: VDC CAN CIR1</li> <li>• U0428: STRG SEN CAN CIR2</li> </ul>
4	<ul style="list-style-type: none"> <li>• C1A03: VEHC_SPEED_SE_CIRC</li> </ul>
5	<ul style="list-style-type: none"> <li>• C1A15: GEAR POSITION</li> </ul>
6	<ul style="list-style-type: none"> <li>• C1A00: CONTROL UNIT</li> <li>• C1A17: ICC SENSOR MALF</li> <li>• C1A0D: RADAR CAN CIR</li> </ul>

## DTC Index

INFOID:000000011952943

### NOTE:

- The details of time display are as per the following.
- 0: The malfunctions that are detected now  
CAN communication system (U1000, U1010)
- 1 - 39: It increases like 0 → 1 → 2 ... 38 → 39 after returning to the normal condition whenever the ignition is switched OFF → ON. It returns to 0 when a malfunction is detected again in the process.
- If it is over 39, it is fixed to 39 until the self-diagnosis results are erased.  
Other than CAN communication system (Other than U1000, U1010)
- 1 - 49: It increases like 0 → 1 → 2 ... 48 → 49 after returning to the normal condition whenever the ignition is switched OFF → ON. It returns to 0 when a malfunction is detected again in the process.
- If it is over 49, it is fixed to 49 until the self-diagnosis results are erased.

# ICC SENSOR

< ECU DIAGNOSIS INFORMATION >

[ICC]

×: Applicable

DTC		ICC system warning lamp	Fail-safe function			Reference
			Intelligent Cruise Control	Predictive Forward Collision Control	Forward Emergency Brake (FEB)	
CONSULT	CONSULT display					
C1A00	CONTROL UNIT	ON	×	×	×	<a href="#">CCS-70, "DTC Description"</a>
C1A0C	ADAS CAN CIR 1	ON	×	×	×	<a href="#">CCS-117, "DTC Description"</a>
C1A0D	RADAR CAN CIR	ON	×	×	×	<a href="#">CCS-118, "DTC Description"</a>
C1A01	POWER SUPPLY CIR	ON	×	×	×	<a href="#">CCS-71, "DTC Description"</a>
C1A02	POWER SUPPLY CIR2	ON	×	×	×	<a href="#">CCS-71, "DTC Description"</a>
C1A03	VHCL SPEED SE CIRC	ON	×	×	×	<a href="#">CCS-72, "DTC Description"</a>
C1A04	ABS/TCS/VDC CIRC	ON	×	×	×	<a href="#">CCS-74, "DTC Description"</a>
C1A05	BRAKE SW/STOP L SW	ON	×	×	×	<a href="#">CCS-75, "DTC Description"</a>
C1A06	OPERATION SW CIRC	ON	×			<a href="#">CCS-79, "DTC Description"</a>
C1A07	CVT CIRCUIT	ON	×	×	×	<a href="#">CCS-114, "DTC Description"</a>
C1A12	LASER BEAM OFFCNTR	ON	×	×	×	<a href="#">CCS-82, "DTC Description"</a>
C1A13	STOP LAMP RLY FIX	ON	×	×	×	<a href="#">CCS-83, "DTC Description"</a>
C1A14	ECM CIRCUIT	ON	×	×	×	<a href="#">CCS-85, "DTC Description"</a>
C10B7	YAW RATE SENSOR	ON	×	×	×	<a href="#">CCS-103, "DTC Description"</a>
C1A15	GEAR POSITION	ON	×	×	×	<a href="#">CCS-87, "DTC Logic"</a>
C1A16	RADAR BLOCKED	ON	×	×	×	<a href="#">CCS-89, "DTC Description"</a>
C1A17	ICC SENSOR MALF	ON	×	×	×	<a href="#">CCS-91, "DTC Description"</a>
C1A18	LASER ALIGNMENT INCMPT	ON	×	×	×	<a href="#">CCS-92, "DTC Description"</a>
C1A21	UNIT HIGH TEMP	ON	×	×	×	<a href="#">CCS-93, "DTC Description"</a>
C1A24	NP RANGE	ON	×	×	×	<a href="#">CCS-94, "DTC Description"</a>

A  
B  
C  
D  
E  
F  
G  
H  
I  
J  
K  
L  
M  
N  
P

CCS

# ICC SENSOR

< ECU DIAGNOSIS INFORMATION >

[ICC]

DTC	CONSULT display	ICC system warning lamp	Fail-safe function			Reference
			Intelligent Cruise Control	Predictive Forward Collision Control	Forward Emergency Brake (FEB)	
C1A26	ECD MODE MALF	ON	×	×	×	<a href="#">CCS-96. "DTC Description"</a>
C1A27	ECD POWER SUPPLY CIRCUIT	ON	×	×	×	<a href="#">CCS-98. "DTC Description"</a>
C1A39	STRG SENS CIR	ON	×	×	×	<a href="#">CCS-100. "DTC Description"</a>
C1A50	ADAS MALFUNCTION	ON	×	×	×	<a href="#">CCS-102. "DTC Description"</a>
C1B5D	FEB OPE COUNT LIMIT	ON	×	×	×	<a href="#">CCS-101. "DTC Description"</a>
C10B7	YAW RATE SENSOR	ON	×	×	×	<a href="#">CCS-103. "DTC Description"</a>
U153A	TCM CAN CIR 1	ON	×	×	×	<a href="#">CCS-115. "DTC Description"</a>
U153B	TCM CAN CIR 2	ON	×	×	×	<a href="#">CCS-116. "DTC Description"</a>
U153D	ECM CAN CIR 2	ON	×	×	×	<a href="#">CCS-116. "DTC Description"</a>
U0121	VDC CAN CIR2	ON	×	×	×	<a href="#">CCS-104. "DTC Description"</a>
U0126	STRG SEN CAN CIR1	ON	×	×	×	<a href="#">CCS-106. "DTC Description"</a>
U0401	ECM CAN CIR1	ON	×	×	×	<a href="#">CCS-107. "DTC Description"</a>
U0415	VDC CAN CIR1	ON	×	×	×	<a href="#">CCS-108. "DTC Description"</a>
U0428	STRG SEN CAN CIR2	ON	×	×	×	<a href="#">CCS-110. "DTC Description"</a>
U1000	CAN COMM CIRCUIT	ON	×	×	×	<a href="#">CCS-111. "DTC Logic"</a>
U1010	CONTROL UNIT (CAN)	ON	×	×	×	<a href="#">CCS-112. "DTC Logic"</a>



< WIRING DIAGRAM >

## WIRING DIAGRAM

### INTELLIGENT CRUISE CONTROL

#### Wiring Diagram

INFOID:000000011952944

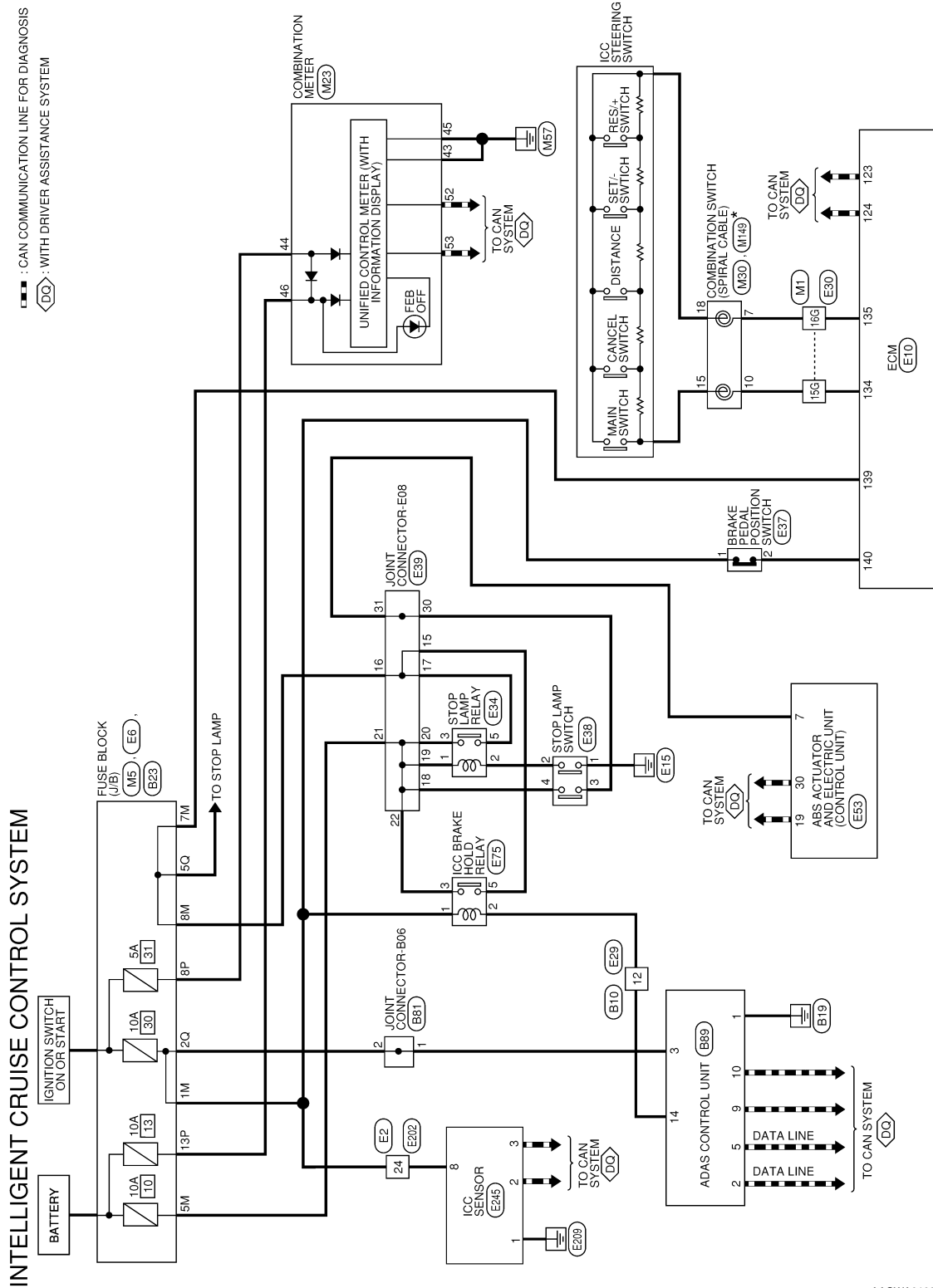

\* : THIS CONNECTOR IS NOT SHOWN IN "HARNES LAYOUT"

AAOWA0109GB

A  
B  
C  
D  
E  
F  
G  
H  
I  
J  
K  
L  
M  
N  
P



INTELLIGENT CRUISE CONTROL SYSTEM CONNECTORS

Connector No.	M1
Connector Name	WIRE TO WIRE
Connector Type	TH80FW-CS16-TM4
Connector Color	WHITE

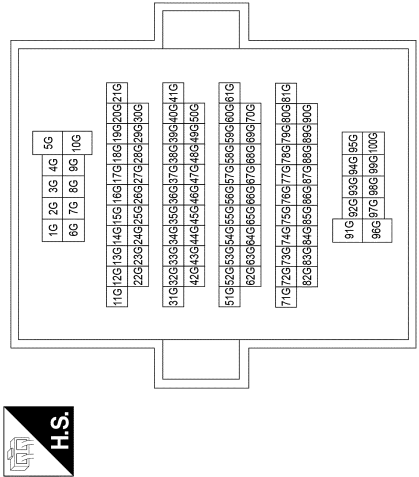

Terminal No.	Color of Wire	Signal Name
15G	BG	-
16G	R	-

Connector No.	M5
Connector Name	FUSE BLOCK (J/B)
Connector Type	NS16FW-CS
Connector Color	WHITE



Terminal No.	Color of Wire	Signal Name
8P	BR	-
13P	G	-

Connector No.	M23
Connector Name	COMBINATION METER
Connector Type	TH16FW-NH
Connector Color	WHITE

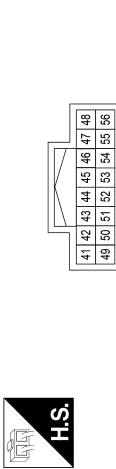

Terminal No.	Color of Wire	Signal Name
43	B	GND1
44	BR	POWER (IGN)
45	B	GND2
46	G	POWER (BAT)
52	P	CAN-L
53	L	CAN-H

Connector No.	M30
Connector Name	COMBINATION SWITCH (SPIRAL CABLE)
Connector Type	TK08FGY-1V
Connector Color	GRAY



Terminal No.	Color of Wire	Signal Name
7	R	-
10	BG	-

Connector No.	M149
Connector Name	COMBINATION SWITCH (SPIRAL CABLE)
Connector Type	TK08FGY-X
Connector Color	GRAY

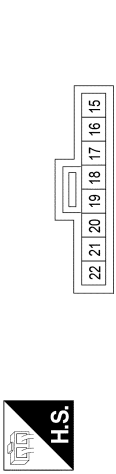

Terminal No.	Color of Wire	Signal Name
15	W	-
18	BR	-

Connector No.	E2
Connector Name	WIRE TO WIRE
Connector Type	TH24MW-NH
Connector Color	WHITE

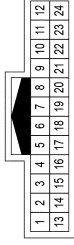

Terminal No.	Color of Wire	Signal Name
24	BG	-

# INTELLIGENT CRUISE CONTROL

< WIRING DIAGRAM >

[ICC]

A  
B  
C  
D  
E  
F  
G  
H  
I  
J  
K  
L  
M  
N  
P

Connector No.	E34
Connector Name	STOP LAMP RELAY
Connector Type	MS02FL-IM2-LC
Connector Color	BLUE



Terminal No.	Color of Wire	Signal Name
1	P	-
2	R	-
3	P	-
5	W	-

Connector No.	E37
Connector Name	BRAKE PEDAL POSITION SWITCH
Connector Type	M02FBR-LC
Connector Color	BROWN



Terminal No.	Color of Wire	Signal Name
1	BG	-
2	BR	-

Connector No.	E29
Connector Name	WIRE TO WIRE
Connector Type	NS16FW-CS
Connector Color	WHITE

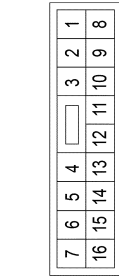

Terminal No.	Color of Wire	Signal Name
12	W	-

Connector No.	E30
Connector Name	WIRE TO WIRE
Connector Type	TH80MM-CS16-TM4
Connector Color	WHITE

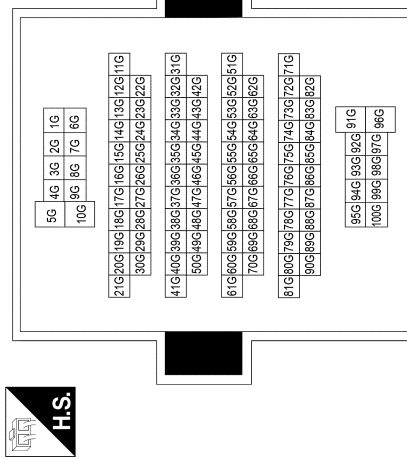

Terminal No.	Color of Wire	Signal Name
15G	G	-
16G	R	-

Connector No.	E6
Connector Name	FUSE BLOCK (J/B)
Connector Type	NS10FW-CS
Connector Color	WHITE

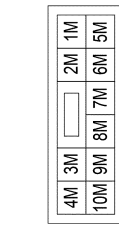

Terminal No.	Color of Wire	Signal Name
1M	BG	-
5M	P	-
7M	GR	-
8M	W	-

Connector No.	E10
Connector Name	ECM
Connector Type	RH24FB-RZ8-L-LH
Connector Color	BLACK

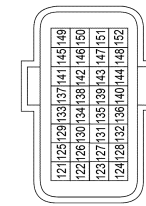

Terminal No.	Color of Wire	Signal Name
123	P	CAN-L
124	L	CAN-H
134	G	ASCD/ICC STEERING SWITCH
135	R	ASCD/ICC STEERING SWITCH GROUND
139	GR	STOP LAMP SWITCH
140	BR	BRAKE PEDAL POSITION SWITCH

# INTELLIGENT CRUISE CONTROL

[ICC]

< WIRING DIAGRAM >

Connector No.	E202
Connector Name	WIRE TO WIRE
Connector Type	TH24FW-NH
Connector Color	WHITE



Terminal No.	Color of Wire	Signal Name
24	BG	-

Connector No.	E245
Connector Name	ICC SENSOR
Connector Type	AAZ08FB
Connector Color	BLACK

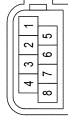

Terminal No.	Color of Wire	Signal Name
1	GR	GND
2	L	ITS CAN-H
3	Y	ITS CAN-L
4	-	-
5	-	-
6	-	-
7	-	-
8	BG	IGN

Connector No.	E63
Connector Name	ABS ACTUATOR AND ELECTRIC UNIT (CONTROL UNIT) (WITH INTELLIGENT CRUISE CONTROL SYSTEM)
Connector Type	SAZ34FB-HS2-SJZ2-UH
Connector Color	BLACK

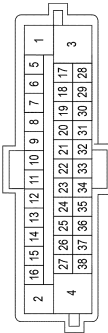

Terminal No.	Color of Wire	Signal Name
7	LG	BLS
19	L	CAN-H
30	P	CAN-L

Connector No.	E75
Connector Name	ICC BRAKE HOLD RELAY
Connector Type	MS02FL-M2-LC
Connector Color	BLUE



Terminal No.	Color of Wire	Signal Name
1	BG	-
2	W	-
3	P	-
5	W	-

Connector No.	E38
Connector Name	STOP LAMP SWITCH
Connector Type	M04FW-LC
Connector Color	WHITE



Terminal No.	Color of Wire	Signal Name
1	B	-
2	R	-
3	LG	-
4	P	-

Connector No.	E39
Connector Name	JOINT CONNECTOR-E08
Connector Type	BJ30FW
Connector Color	WHITE

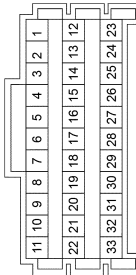

Terminal No.	Color of Wire	Signal Name
15	W	-
16	W	-
17	W	-
18	P	-
19	P	-
20	P	-
21	P	-
22	P	-
30	LG	-
31	LG	-

AAOIA0375GB

# INTELLIGENT CRUISE CONTROL

< WIRING DIAGRAM >

[ICC]

A  
B  
C  
D  
E  
F  
G  
H  
I  
J  
K  
L  
M  
N  
P

Connector No.	B89
Connector Name	ADAS CONTROL UNIT
Connector Type	TH24FW-NH
Connector Color	WHITE

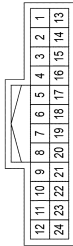

Terminal No.	Color of Wire	Signal Name
1	B	GND
2	L	ITS CAN-H
3	BG	IGN
5	Y	ITS CAN-L
9	L	CAN-H
10	P	CAN-L
14	W	BRAKE RELAY

Connector No.	B10
Connector Name	WIRE TO WIRE
Connector Type	NS16MW-CS
Connector Color	WHITE

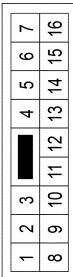

Terminal No.	Color of Wire	Signal Name
12	W	-

Connector No.	B23
Connector Name	FUSE BLOCK (J/B)
Connector Type	NS08FW-CS
Connector Color	WHITE

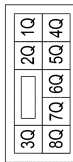

Terminal No.	Color of Wire	Signal Name
2Q	BG	-
5Q	L	-

Connector No.	B81
Connector Name	JOINT CONNECTOR-B06
Connector Type	A12FL
Connector Color	BLUE

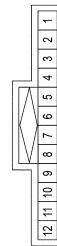

Terminal No.	Color of Wire	Signal Name
1	BG	-
2	BG	-

AAOIA0376GB



# DIAGNOSIS AND REPAIR WORK FLOW

< BASIC INSPECTION >

[ICC]

## BASIC INSPECTION

### DIAGNOSIS AND REPAIR WORK FLOW

Work Flow

INFOID:000000011952945

#### OVERALL SEQUENCE

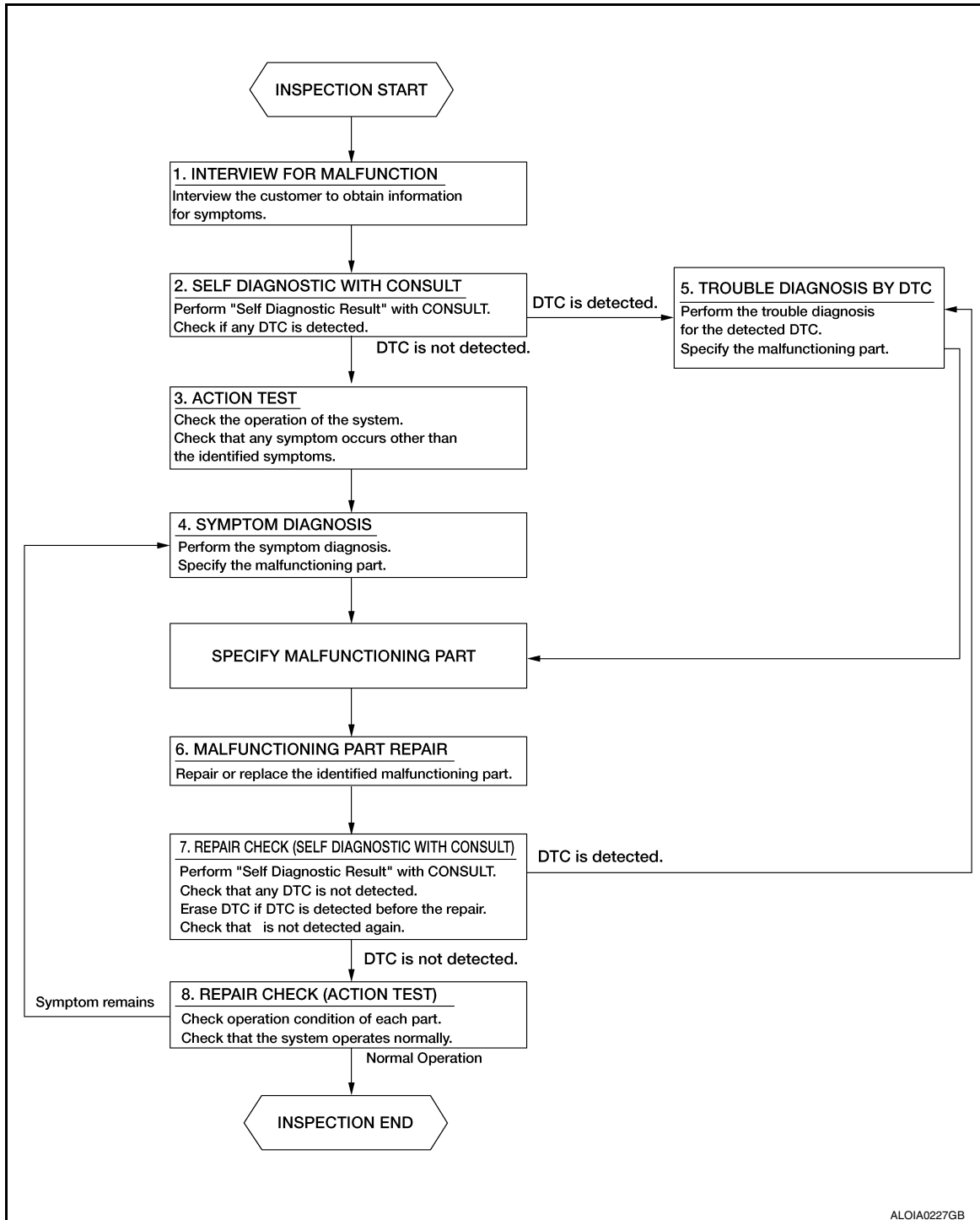

#### DETAILED FLOW

### 1. INTERVIEW FOR MALFUNCTION

It is important to clarify the customer's concerns before starting the inspection. Interview the customer about the concerns carefully and understand the symptoms fully.

# DIAGNOSIS AND REPAIR WORK FLOW

[ICC]

< BASIC INSPECTION >

## NOTE:

The customers are not professionals. Never assume that “maybe the customer means...” or “maybe the customer mentioned this symptom”.

>> GO TO 2.

## 2. SELF DIAGNOSTIC RESULT WITH CONSULT

### CONSULT

1. Select “Self Diagnostic Result” mode of “LASER/RADAR”.
2. Check if the DTC is detected in the “Self Diagnostic Result” mode of “LASER/RADAR”.

Is any DTC detected?

- YES >> GO TO 5.  
NO >> GO TO 3.

## 3. ACTION TEST

Perform the FEB system action test to check the system operation. Check if any other malfunctions occur.

>> GO TO 4.

## 4. SYMPTOM DIAGNOSIS

Perform the applicable diagnosis according to the diagnosis chart by symptom. Refer to [CCS-119, "Symptom Table"](#).

>> GO TO 6.

## 5. TROUBLE DIAGNOSIS BY DTC

1. Check the DTC in the “Self Diagnostic Result”.
2. Perform trouble diagnosis for the detected DTC. Refer to [CCS-46, "DTC Index"](#).

>> GO TO 6.

## 6. MALFUNCTIONING PART REPAIR

Repair or replace the identified malfunctioning parts.

>> GO TO 7.

## 7. REPAIR CHECK (SELF DIAGNOSTIC RESULT WITH CONSULT)

### CONSULT

1. Erase “Self Diagnostic Result”.
2. Select “Self Diagnostic Result” again after repairing or replacing the specific items.
3. Check if any DTC is detected in “Self Diagnostic Result” mode of “LASER/RADAR”.

Is any DTC detected?

- YES >> GO TO 5.  
NO >> GO TO 8.

## 8. REPAIR CHECK (ACTION TEST)

Perform the FEB system action test. Check that the malfunction symptom is solved or no other symptoms occur.

Is there a malfunction symptom?

- YES >> GO TO 4.  
NO >> Inspection End.

## ADDITIONAL SERVICE WHEN REPLACING ICC SENSOR

< BASIC INSPECTION >

[ICC]

---

### ADDITIONAL SERVICE WHEN REPLACING ICC SENSOR

#### Description

INFOID:000000011952946

- Always perform the radar alignment aiming adjustment after removing and installing or replacing the ICC sensor.

**CAUTION:**

**The system does not operate normally unless the ICC sensor is aligned properly.**

- Perform the ICC system action test to check that the ICC system operates normally.

#### Work Procedure

INFOID:000000011952947

#### 1. RADAR ALIGNMENT ADJUSTMENT

---

Adjust the radar alignment. Refer to [CCS-59. "Description"](#).

>> GO TO 2.

#### 2. ICC SYSTEM ACTION TEST

- 
1. Perform the ICC system action test. Refer to [CCS-66. "Description"](#).
  2. Check that the ICC system operates normally.

>> Inspection End.



# ICC SENSOR INITIAL VERTICAL ALIGNMENT

< BASIC INSPECTION >

[ICC]

## ICC SENSOR INITIAL VERTICAL ALIGNMENT

### Description

INFOID:0000000011952948

#### **WARNING:**

Radio waves could adversely affect electric medical equipment. Those who use a pacemaker should contact the electric medical equipment manufacturer for the possible influences before use.

#### OUTLINE OF ICC SENSOR INITIAL ALIGNMENT PROCEDURE

- Always perform the ICC sensor initial vertical alignment after removing and installing or replacing the ICC sensor.

#### **CAUTION:**

The system does not operate normally unless the ICC sensor is aligned properly.

1. For required tools, refer to [CCS-57, "Required Tools"](#).
2. For preparation, refer to [CCS-57, "Preparation"](#).
3. For ICC sensor initial vertical alignment, refer to [CCS-58, "ICC Sensor Initial Vertical Alignment"](#).

#### CAUTIONARY POINT FOR DISTANCE SENSOR ALIGNMENT PROCEDURE

#### **CAUTION:**

- For Distance sensor alignment procedure, choose a level location with a few feet of working space in front and surrounding the vehicle.
- Vehicle must be stationary and unoccupied during the whole alignment procedure.
- Never enter the vehicle during ICC sensor alignment.
- For proper system operation and adjustment, all vehicle wheels must be the original factory size.

The ICC sensor requires alignment whenever the ICC sensor is removed and reinstalled and whenever front end structural repairs are performed. ICC sensor alignment consists of performing the mechanical vertical alignment (ICC sensor initial vertical alignment) described in the following procedure, followed by the electronic horizontal alignment (ICC sensor alignment) that is performed using CONSULT and the appropriate special service tools.

### Required Tools

INFOID:0000000011952949

The following tool is necessary to perform the ICC sensor initial vertical alignment:

- Small level or angle meter.

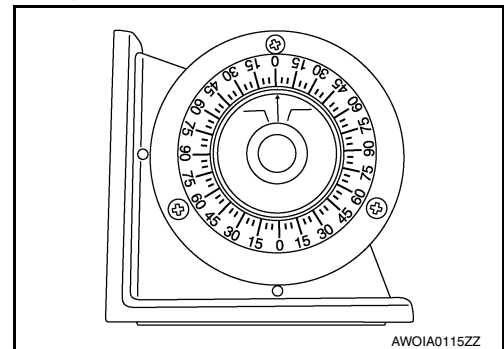

### Preparation

INFOID:0000000011952950

#### 1. PREPARATION FOR ICC SENSOR INITIAL VERTICAL ALIGNMENT PROCEDURE

1. Verify correct vehicle suspension height. Refer to [FSU-24, "Wheelarch Height \(Unladen\\*<sup>1</sup>\)"](#).
2. Repair or replace any damaged body components.
3. Verify proper tire inflation pressures. Refer to [WT-73, "Tire"](#).
4. Remove any accumulations of mud, snow or ice from the vehicle underbody.
5. Verify that there is no load in the vehicle (cargo or passenger).
6. Place the vehicle on a known level horizontal surface such as a wheel or frame alignment rack to achieve satisfactory sensor vertical alignment results.

A  
B  
C  
D  
E  
F  
G  
H  
I  
J  
K  
L  
M  
N

CCS

P

# ICC SENSOR INITIAL VERTICAL ALIGNMENT

< BASIC INSPECTION >

[ICC]

>> Refer to [CCS-58. "ICC Sensor Initial Vertical Alignment"](#).

## ICC Sensor Initial Vertical Alignment

INFOID:000000011952951

### NOTE:

The ICC sensor initial vertical alignment procedure must be performed anytime the distance sensor is removed and reinstalled.

1. The ICC sensor (1) is located near the right front headlamp behind the front bumper fascia.

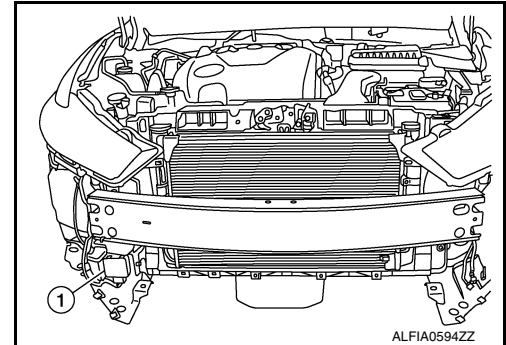

2. Place the small level or angle meter (2) against the face of the ICC sensor (1).

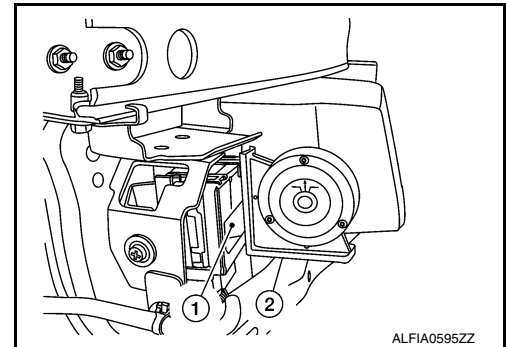

3. Turn the ICC sensor adjustment screw (1) to level the sensor.

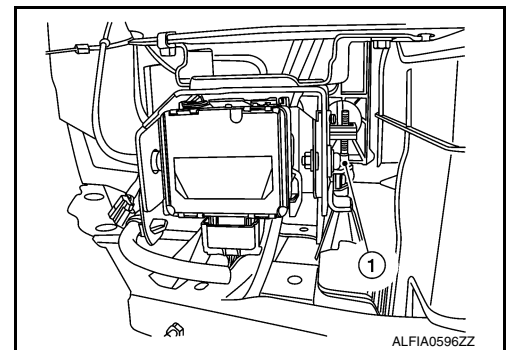

4. Ensure the ICC sensor electrical connector located on the bottom of the sensor is connected.
5. Perform the ICC sensor alignment procedure. Refer to [CCS-59. "Description"](#).

# ICC SENSOR ALIGNMENT

< BASIC INSPECTION >

[ICC]

## ICC SENSOR ALIGNMENT

### Description

INFOID:0000000011952952

#### **WARNING:**

Radio waves could adversely affect electric medical equipment. Those who use a pacemaker should contact the electric medical equipment manufacturer for the possible influences before use.

#### OUTLINE OF ICC SENSOR ALIGNMENT PROCEDURE

- A 4-wheel vehicle alignment must be performed before proceeding with ICC sensor alignment procedure.
- Always perform the ICC sensor alignment after removing and installing or replacing the ICC sensor.
- If the ICC sensor was removed and installed or replaced, first perform ICC Sensor Initial Vertical Alignment, refer to [CCS-59, "Description"](#).

#### **CAUTION:**

The system does not operate normally unless the ICC sensor is aligned properly.

1. For required tools, refer to [CCS-59, "Required Tools"](#).
2. For preparation, refer to [CCS-60, "Preparation"](#).
3. For vehicle set up, refer to [CCS-61, "Vehicle Set Up"](#).
4. For setting the ICC target board, refer to [CCS-63, "Setting The ICC Target Board"](#).
5. For ICC sensor adjustment, refer to [CCS-64, "ICC Sensor Adjustment"](#).

#### CAUTIONARY POINT FOR ICC SENSOR ALIGNMENT PROCEDURE

#### **CAUTION:**

- For ICC sensor alignment procedure, choose a level location with a few feet of working space in front and surrounding the vehicle.
- Vehicle must be stationary and unoccupied during the whole alignment procedure.
- Any slight vibration during the alignment procedure can cause the test to fail. If this happens, you will have to restart the alignment process.
- The ignition switch must be in the ON position.
- The battery voltage must not fall below 12 volts during the whole alignment procedure. Failure to maintain adequate battery voltage will cause the test to fail. If this happens, you will have to restart the alignment process.
- The ICC target board must be set in front of the vehicle facing the sensor.
- Adjust the ICC sensor alignment with CONSULT. (The ICC sensor alignment procedure cannot be adjusted without CONSULT.)
- Never enter the vehicle during ICC sensor alignment.
- Never block the area between the ICC sensor and the ICC target board at any time during the alignment process.
- Never break the laser beam between the laser assembly and front ICC target board or rear reflector at any time during alignment.
- Accurate steering wheel setting is crucial. Once set, do not disturb the steering wheel for the remainder of the alignment procedure.
- To avoid physical damage, the ICC sensor adjustment screw must not be forced to either clockwise or counter-clockwise limit. For proper adjustment procedure, follow the directions of the CONSULT exactly as instructed.
- For proper system operation and adjustment, all vehicle wheels must be of the same size.

### Required Tools

INFOID:0000000011952953

- ICC alignment kit 1-20-2721-1-IF in addition to one of the following:
  - a) Hunter self-centering wheel adapter (Hunter wheel alignment tool)
  - b) Special Service Tool kit 1-20-2722-1-IF (kit SCA W/Tire Clamp-ICC Aiming)

The following ICC alignment kit 1-20-2721-1-IF is necessary to perform the ICC sensor alignment:

A  
B  
C  
D  
E  
F  
G  
H  
I  
J  
K  
L  
M  
N  
P

# ICC SENSOR ALIGNMENT

[ICC]

## < BASIC INSPECTION >

- ICC target board.
  - Position 1, with top tilted 2° toward vehicle (1).
  - Position 2, vertical (2).
  - Position 3, with top tilted 2° away from vehicle (3).

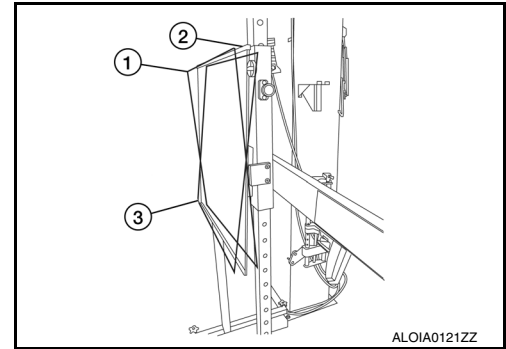

- Hunter self-centering wheel adapter (1) [shown with laser assembly (2) installed]. (Hunter alignment rack head may be substituted.)

### NOTE:

When the power switch is turned ON, the front laser signal (A) will be emitted toward the front ICC target board, and the rear laser signal (B) will be emitted toward the rear of the vehicle.

### NOTE:

Retailers that are not equipped with a Hunter self-centering wheel adapter will require the following kit:

Part No. 1-20-2722-1-IF (kit SCA W/Tire Clamp-ICC Aiming)

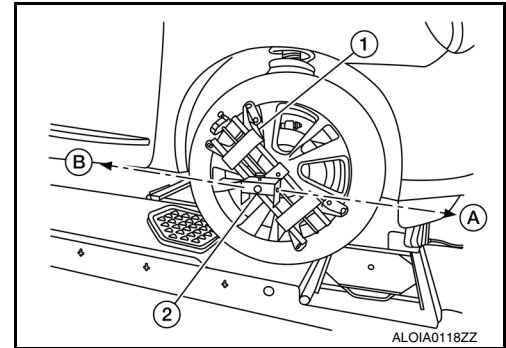

- Laser assembly (with bi-directional laser beam) as shown in the illustration.

- Tightening knob (1)
- Power ON/OFF button (2)
- Front laser beam opening (3)
- Rear laser beam opening (4)
- Attaching shaft (5)

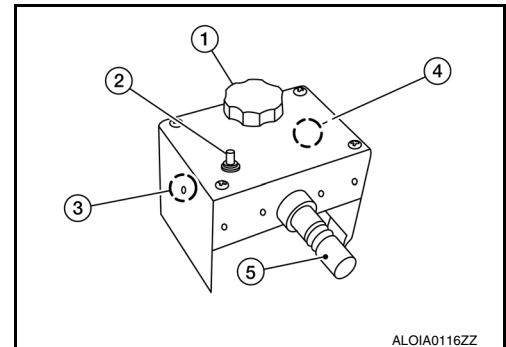

- Stationary target as shown in the illustration.

- Stationary target (1)
- Laser signal reception plate (2)

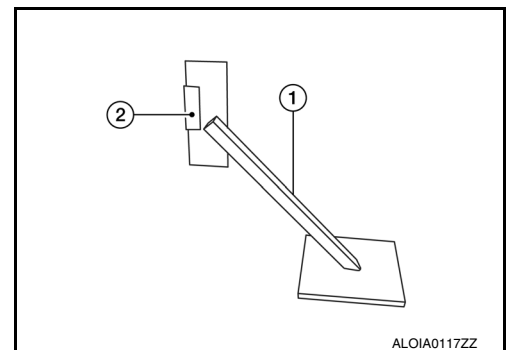

- Distance chain (not shown).

## Preparation

INFOID:000000011952954

### 1. ADVANCE PREPARATION FOR ICC SENSOR ALIGNMENT PROCEDURE

1. Adjust all tire pressures to the specified value.
2. Empty the vehicle. (Remove any luggage from the passenger compartment, luggage room, etc.)
3. Shift the selector lever to "P" position, and release the parking brake.
4. Fully fill the fuel tank, and then check that the coolant and oils are filled to correct level.
5. Clean off the front of the ICC sensor.

# ICC SENSOR ALIGNMENT

< BASIC INSPECTION >

[ICC]

**NOTE:**

The ICC sensor (1) is located behind the fascia and it is not exposed to the elements. Therefore, it should not require any cleaning.

1 : ICC sensor

>> Refer to [CCS-61. "Vehicle Set Up"](#).

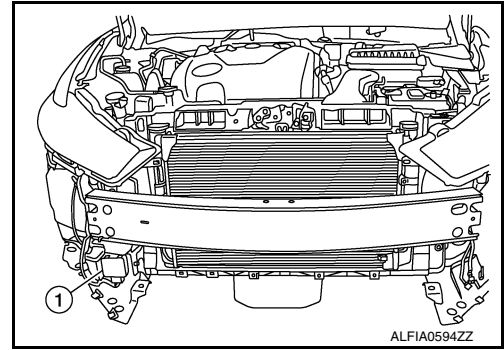

## Vehicle Set Up

INFOID:000000011952955

### DESCRIPTION

Accurate adjustment of the ICC sensor alignment requires that the ICC target board, wheel adapter, laser assembly, and stationary target be properly positioned.

**CAUTION:**

If the ICC sensor alignment is adjusted with the ICC target board, wheel adapter, laser assembly, or stationary target in the incorrect position, the ICC system will not function properly or the alignment procedure may not be completed successfully.

### 1. PREPOSITION TARGET BOARD

**NOTE:**

- The center of the sensor wave axis (A) is located at the center of the front lens.

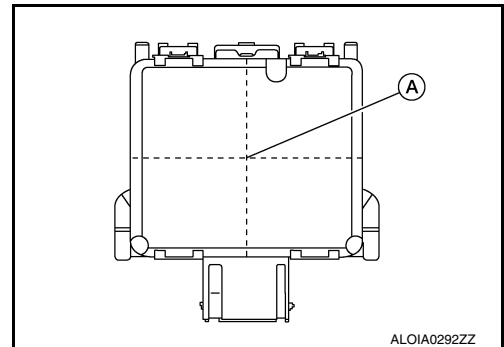

- Initial ICC target board setting must be in the center position.

1. Position the ICC target board in front facing the right front side of the vehicle:
  - Using the full length of the supplied chain for distance, place the marked center of the ICC target board (1) 1200 mm (47.2 in.)  $\pm$  625 mm (24.6 in) facing the ICC sensor.
  - Adjust the height of the ICC target board using the adjustable nut (2) to achieve the proper height. The up/down tolerance is  $\pm$  80 mm (3.15 in).
  - Adjust the ICC target board lateral position aligning the marked center of the board horizontally with the center of the ICC sensor front lens. The right/left tolerance is  $\pm$  80 mm (3.15 in).
2. Extend the machined arm of the ICC target board exposing the reflective surface (3) to the right front side of the vehicle.

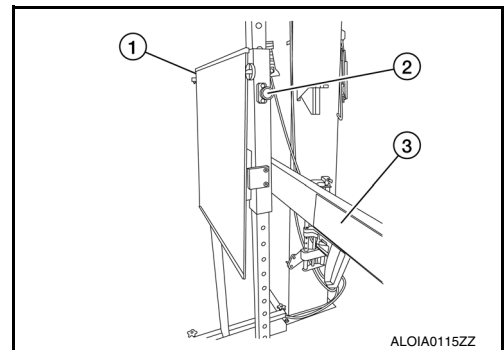

A  
B  
C  
D  
E  
F  
G  
H  
I  
J  
K  
L  
M  
N  
P

CCS

# ICC SENSOR ALIGNMENT

[ICC]

## < BASIC INSPECTION >

- Place one side of the laser assembly (2) flush against the center of the ICC target board (1) to assist in the positioning.

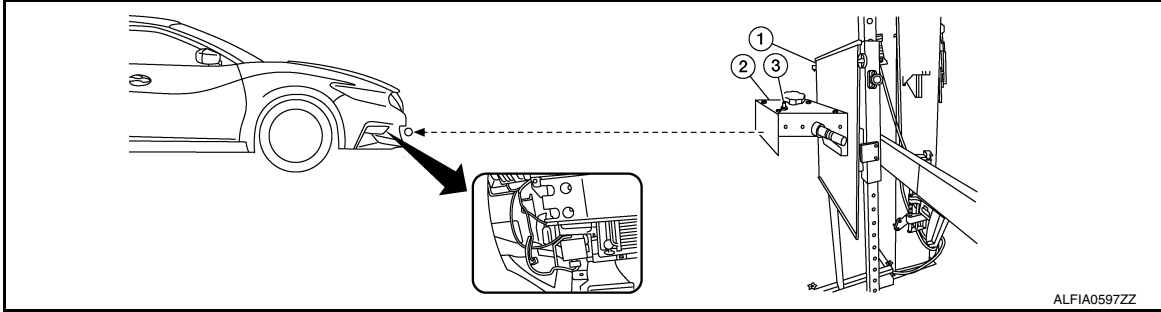

- Turn the laser assembly ON (3) allowing the laser beam to emit through the opening of the laser assembly toward the center of the ICC sensor.
- Move the ICC target board (1) as necessary so that center of ICC target board aligns with center of ICC sensor.
- Turn the laser assembly OFF when done.

### Are you using Hunter alignment equipment?

- YES >> Refer to Hunter's equipment instructions for complete vehicle set up and ICC target board setting. Then, refer to [CCS-64. "ICC Sensor Adjustment"](#).
- NO >> GO TO 2.

## 2. INSTALLING LASER ASSEMBLY

### NOTE:

- Ensure the steering wheel is positioned in the center straight-forward position.
  - Ensure all four vehicle wheels do not have any physical damage.
- Install the wheel adapter (1) on the right front wheel.
  - Mount the laser assembly (2) to the wheel adapter (1) as shown in the figure.

### NOTE:

When the power switch is turned ON, the front laser signal (A) will be emitted toward the front ICC target board, and the rear laser signal (B) will be emitted toward the rear of the vehicle.

>> GO TO 3.

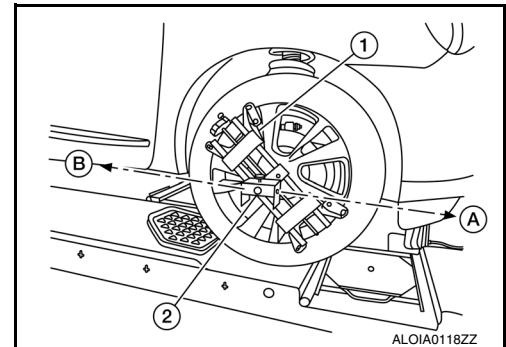

## 3. SETTING UP STATIONARY TARGET

- Place the stationary target next to the right rear tire as shown in the figure.
- Turn the laser assembly ON allowing the laser beam to be emitted through the front and rear laser assembly openings.
- Measure and record the distance ( $D_r$ ) between the edge of the right rear wheel and the laser beam (1) on the stationary target (horizontal line).
- Measure and record the height ( $H_r$ ) between the laser beam (1) on the stationary target and ground level (vertical line).

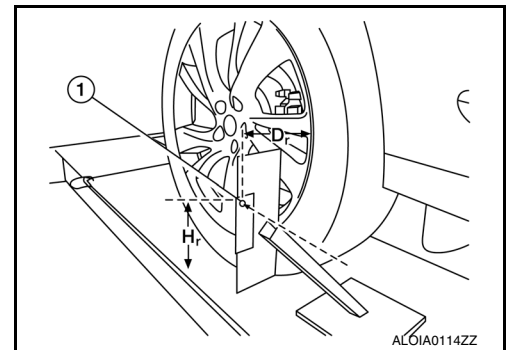

# ICC SENSOR ALIGNMENT

[ICC]

## < BASIC INSPECTION >

5. Measure and record the distance ( $D_f$ ) between the edge of the right front wheel and the laser beam signal/opening (1) on the laser assembly (horizontal line).
6. Measure and record the height ( $H_f$ ) between the laser beam signal/opening (1) on the laser assembly and ground level (vertical line).

### NOTE:

- Horizontal adjustment [front distance ( $D_f$ ) and rear distance ( $D_r$ )] is accomplished by slowly turning the steering wheel until the 2 distances are the same.
- Vertical adjustment [front height ( $H_f$ ) and rear height ( $H_r$ )] is accomplished by rotating the laser assembly around its axis until the two heights are the same.
- Directional arrows (A) and (B) are shown to illustrate the direction of the laser assembly beams.

7. Adjust laser beam as necessary until the two distances match and the two heights match.

### NOTE:

You will have to verify both horizontal and vertical adjustments anytime one adjustment is made.

>> Refer to [CCS-63, "Setting The ICC Target Board"](#).

## Setting The ICC Target Board

INFOID:000000011952956

### DESCRIPTION

Accurate adjustment of the ICC sensor alignment requires that the ICC target board be accurately positioned.

### CAUTION:

If the ICC sensor alignment is adjusted with the ICC target board in the incorrect position, the ICC system will not function properly or the alignment procedure may not be completed successfully.

## 1. ICC TARGET BOARD FINAL SETTING

1. With the ICC target board arm extended, the laser beam (1) emitted by the laser assembly (A) will be reflected back (B) toward the laser assembly.

### NOTE:

When adjusted properly, reflected laser beam (B) must align with emitted laser beam (A) and the two laser beams will be seen as one.

2. Rotate the ICC target board to achieve the necessary horizontal adjustment.
3. Adjust the ICC target board leveling screws to achieve the necessary vertical adjustment.

4. The figure shown illustrates the laser beam (A) emitted by the laser assembly (1) and its reflection (B) off the ICC target board arm.

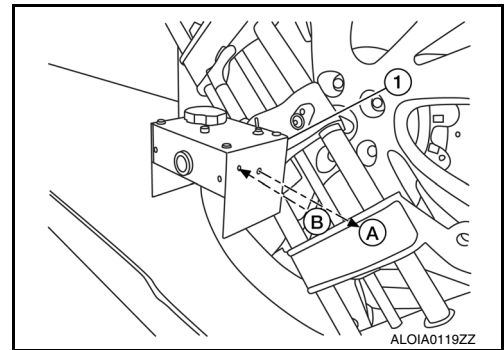
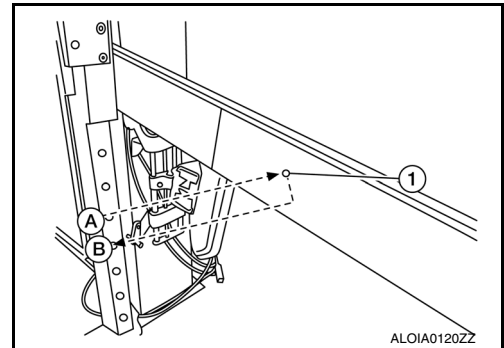
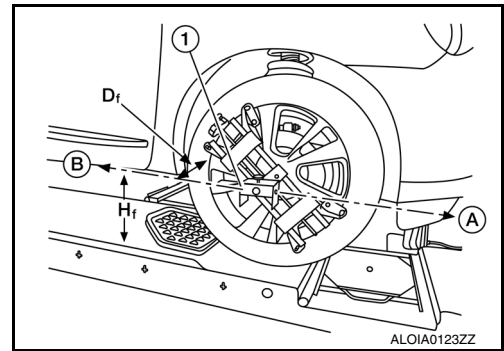

>> GO TO 2.

## 2. CHECK THE POSITION OF THE ICC TARGET BOARD

A  
B  
C  
D  
E  
F  
G  
H  
I  
J  
K  
L  
M  
N  
P

CCS

# ICC SENSOR ALIGNMENT

[ICC]

## < BASIC INSPECTION >

Do not place anything other than the ICC target board in the space shown in front of the vehicle (view from top).

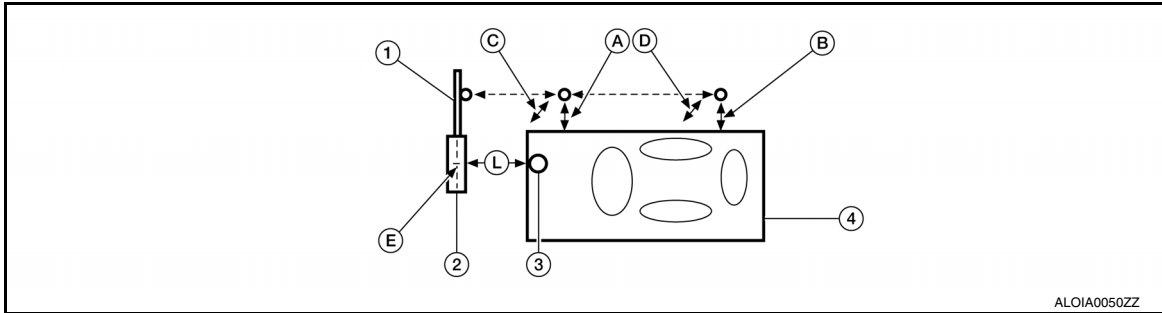

- |   |  |   |
|---|--|---|
| 1. ICC target board arm                                 | 2. ICC target board                                      | 3. ICC sensor   |
| 4. Vehicle  | A. Distance between front wheel and laser beam ( $D_f$ ) | B. Distance between rear wheel and laser beam ( $D_r$ ) |
| C. Height between front laser beam and ground ( $H_f$ ) | D. Height between rear laser beam and ground ( $H_r$ )   | E. ICC target board center position (Position 2)        |
| L. 1 - 1.5 m (39.3 - 59 in.)                            |  |   |

>> Refer to [CCS-64. "ICC Sensor Adjustment"](#).

## ICC Sensor Adjustment

INFOID:000000011952957

### DESCRIPTION

- Adjust the ICC sensor alignment in a vertical direction with CONSULT as per the following.
- The ICC sensor alignment in the horizontal direction is performed automatically and cannot be adjusted manually.

#### **CAUTION:**

- **Never look directly into or block the ICC sensor source (between the front fascia and ICC target board) during the ICC sensor alignment procedure.**
- **Perform all necessary work for ICC sensor alignment procedure until the adjustment completes as shown in the procedure. If the procedure is started but not completed, the ICC system is rendered inoperable.**

### 1. SET CONSULT TO THE ICC SENSOR ALIGNMENT MODE

#### CONSULT

1. Place ignition switch in the ON position.
2. Connect CONSULT and select "LASER/RADAR" then "Work support".
3. Select "RADAR Alignment".
4. Select "Start" after the "RADAR Alignment" screen is displayed.

#### **NOTE:**

If the adjustment screen does not appear or an error appears within approximately 10 seconds after "RADAR Alignment" is selected, the following causes are possible:

- The ICC target board is not installed in the correct position.
- Adequate space is not secured around the ICC target board.
- The ICC sensor alignment procedure exceeds its proper installation range.
  - Deformation of vehicle body.
  - Deformation of unit.
  - Deformation of bracket.
- The area is not suitable for the adjustment work.
- Right front side of fascia (ICC sensor view) is not clean.
- The ICC system warning lamp illuminates.
- Battery voltage is low.
- The extended arm and mirror are not stationary.

>> GO TO 2.

### 2. ICC SENSOR ALIGNMENT



# ICC SENSOR ALIGNMENT

[ICC]

## < BASIC INSPECTION >

1. Once the ICC sensor alignment procedure is started, you will be prompted by CONSULT for the next instruction.
2. Follow all the instructions exactly as requested by CONSULT which will include the following:
  - Adjust ICC target board to position 1 (top tilted toward vehicle).
  - Adjust ICC target board to position 2 (vertical position).
  - Adjust ICC target board to position 3 (top tilted away from vehicle).

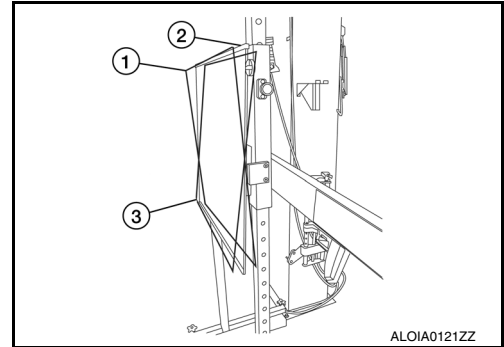

3. You will be prompted with specific instructions to perform physical adjustment to the sensor which may include turning the adjustment screw (1) by a certain number of turns in increments of 0.25 in either direction.

### NOTE:

CONSULT is not live and will not automatically update while turning the tool.

### CAUTION:

**Be careful not to cover the right front side of the fascia (ICC sensor view) with a hand or any other body part during adjustment.**

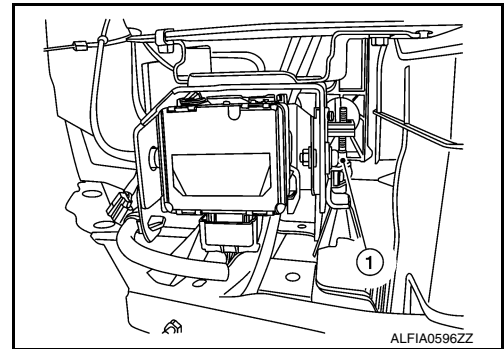

>> GO TO 3.

## 3. ICC SENSOR ALIGNMENT CONFIRMATION

### CONSULT

1. When the "U/D CORRECT" value is executed and the "ADJ VALUE" has been performed, touch "End".
2. When "COMPLETED THE VERTICAL AIMING OF LASER BEAM" display appears, touch "End".

**CAUTION:**  
**Always check that the value of "U/D CORRECT" remains accurate (within specification) when the ICC sensor is left alone for at least 2 seconds.**
3. Check that "ADJUSTING AUTOMATIC HORIZONTAL LASER BEAM AIMING" is displayed and wait for a short period of time. (The maximum: Approx. 10 seconds).
4. Check that "Normally Completed" is displayed, and select "End" to end "RADAR Alignment".

**CAUTION:**  
**Once "RADAR Alignment" is started with CONSULT, always continue the work until the ICC sensor alignment is completed successfully. If the job is stopped midway, the ICC sensor alignment is not completed and the ICC system is rendered inoperative.**
5. Confirm proper ICC sensor alignment by following CONSULT steps until it shows "ADJ VALUE" to be 0.00 turn.

>> Alignment End.

A  
B  
C  
D  
E  
F  
G  
H  
I  
J  
K  
L  
M  
N  
P

CCS

## ACTION TEST

### Description

INFOID:000000011952958

Always perform the ICC system action test to check that the ICC system operates normally after replacing the ICC sensor or repairing any ICC system malfunction.

**CAUTION:**

- Always drive safely when performing the action test.

### Work Procedure

INFOID:000000011952959

**NOTE:**

- When there is no vehicle ahead, drive at the set speed steadily.
- When there is a vehicle ahead, control to maintain distance from the vehicle ahead, watching its speed.
- The running speed can be set between 32 km/h (20 MPH) and 144 km/h (90 MPH).

**CAUTION:**

**Never set the cruise speed exceed the posted speed limit.**

#### 1. CHECK FOR MAIN SWITCH

1. Start the engine.
2. Press the MAIN switch (1) (for less than 1.5 seconds).

Information display status		“___”
Set vehicle speed indicator (2)	:	“km/h” (“MPH”)
Set distance indicator (3)	:	Long mode
MAIN switch indicator (4)	:	ON

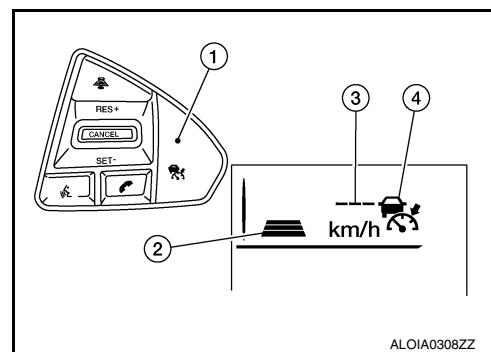

3. Check the ICC system display on the information display to check that the Intelligent Cruise Control is ready for activation.
4. Press the MAIN switch, and check that the ICC system display on the information display turns OFF when the ICC system is deactivated.
5. Check that the ICC system display on the information display turns OFF after starting the engine again.

>> GO TO 2.

#### 2. CHECK FOR DISTANCE SWITCH



1. Start the engine.
2. Press the MAIN switch (for less than 1.5 seconds).
3. Press the DISTANCE switch.

# ACTION TEST

< BASIC INSPECTION >

[ICC]

4. Check that the set distance indicator changes display in order of: (Long)→(Middle)→(Short).

Distance	Display	Approximate distance at 100 km/h (60 MPH) [m (ft)]
Long	 100 km/h	55 (180)
Middle	 100 km/h	40 (130)
Short	 100 km/h	25 (80)

AWOIA0135GB

**NOTE:**

When the MAIN switch is turned ON, initial setting is set to (Long).

>> GO TO 3.

### 3. CHECK FOR RES/+, SET/-, AND CANCEL SWITCHES

1. Check that RES/+, SET/-, and CANCEL switches are operated smoothly.
2. Check that switches come up as hand is released from the switches.

>> GO TO 4.

### 4. SET CHECKING (1)

1. Start the engine.
2. Press the MAIN switch (for less than 1.5 seconds) and turn the Intelligent Cruise Control ON.
3. Drive the vehicle at 32 km/h (20 MPH) or more.
4. Push down the SET/- switch.
5. Check that the desired speed is set and Intelligent Cruise Control starts when releasing SET/- switch.

**NOTE:**

The set vehicle speed is indicated on the set vehicle speed indicator in the Intelligent Cruise Control display on the information display.

>> GO TO 5.

### 5. CHECK FOR INCREASE OF CRUISING SPEED (1)

1. Set the Intelligent Cruise Control at desired speed.
2. Check that the set speed increases by 1 km/h (1 MPH) as RES/+ switch is pushed up.

**NOTE:**

The maximum set speed of the Intelligent Cruise Control is 144 km/h (90 MPH).

**CAUTION:**

**Never set the cruise speed exceed the posted speed limit.**

>> GO TO 6.

### 6. CHECK FOR DECREASE OF CRUISING SPEED (1)

1. Set the Intelligent Cruise Control at desired speed.
2. Check that the set speed decreases by 1 km/h (1 MPH) as SET/- switch is pushed down.

**NOTE:**

- The minimum set speed is approximately 32 km/h (20 MPH).

A  
B  
C  
D  
E  
F  
G  
H  
I  
J  
K  
L  
M  
N  
P

CCS

## ACTION TEST

< BASIC INSPECTION >

[ICC]

- Cancels the control automatically when the vehicle speed is less than approximately 24 km/h (15 MPH) and when the system does not detect any vehicle ahead.

>> GO TO 7.

### 7.SET CHECKING (2)

---

1. Stop the vehicle.
2. Drive the vehicle at less than approximately 32 km/h (20 MPH).
3. Push down the SET/- switch when the system detects a vehicle ahead.
4. Check that the Intelligent Cruise Control is performed so that the vehicle maintains a proper distance according to the vehicle speed [Maximum: approximately 32 km/h (20 MPH)] when releasing SET/- switch.

**NOTE:**

- The Intelligent Cruise Control cannot be set when the vehicle speed is less than 32 km/h (20 MPH) and when a vehicle ahead is not detected.
- Cancels the control automatically when the vehicle speed is 24 km/h (15 MPH) or less during the control and when the system does not detect any vehicle ahead.
- The set vehicle speed indicator in the ICC system display on the information display is set to 32 km/h (20 MPH).

>> GO TO 8.

### 8.CHECK FOR INCREASE OF CRUISING SPEED (2)

---

1. Set the Intelligent Cruise control when the vehicle speed is less than approximately 32 km/h (20 MPH) and when a vehicle ahead is detected.
2. Check that the set speed increases by 1 km/h (1 MPH) as RES/+ switch is pushed up.

**NOTE:**

The maximum set speed of the Intelligent Cruise Control is 144 km/h (90 MPH).

**CAUTION:**

**Never set the cruise speed to exceed the posted speed limit.**

>> GO TO 9.

### 9.CHECK FOR DECREASE OF CRUISING SPEED (2)

---

1. Set the Intelligent Cruise Control when the vehicle speed is less than approximately 32 km/h (20 MPH) and when a vehicle ahead is detected.
2. Set vehicle speed to the desired vehicle speed "check for increase of cruising speed".
3. Check that the set speed decreases by 1 km/h (1 MPH) as SET/- switch is pushed down.

**NOTE:**

- The minimum set speed is approximately 32 km/h (20 MPH).
- If the vehicle ahead comes to a stop, the vehicle decelerates to a standstill within the limitations of the system. The system will cancel once it judges a standstill with a warning chime.

>> GO TO 10.

### 10.CHECK FOR CANCELLATION OF INTELLIGENT CRUISE CONTROL

---

Check that the Intelligent Cruise Control is canceled when performing the following operations:

- When the brake pedal is depressed after Intelligent Cruise Control is set and the vehicle is driven.
- When the selector lever is in the "N" position after Intelligent Cruise control is set and the vehicle is driven.
- When the MAIN switch is turned OFF after Intelligent Cruise Control is set and the vehicle is driven.
- When the CANCEL switch is pressed after Intelligent Cruise Control is set and the vehicle is driven.

>> GO TO 11.

### 11.CHECK FOR RESTORING SPEED THAT IS SET BY INTELLIGENT CRUISE CONTROL BEFORE CANCELLATION

---

Check that the vehicle restores the previous speed kept before the system deactivation when performing the following operations:

## ACTION TEST

< BASIC INSPECTION >

[ICC]

- Drive the vehicle when the Intelligent Cruise Control is set and depress the brake pedal to cancel the control. Check that the vehicle restores the previous vehicle speed kept before the system deactivation when pushing up the RES/+ switch. A
- Drive the vehicle when the Intelligent Cruise Control is set and shift the selector lever to the “N” position to cancel the control. Check that the vehicle restores the previous vehicle speed kept before the system deactivation when shifting the selector lever to the “D” position and pushing up the RESUME/+ switch. B
- Drive the vehicle when the Intelligent Cruise Control is set and press the CANCEL switch to cancel the control. Check that the vehicle restores the previous vehicle speed kept before the system deactivation when pushing up the RESUME/+ switch. C

>> Inspection End.

D

E

F

G

H

I

J

K

L

M

N

CCS

P

# C1A00 CONTROL UNIT

< DTC/CIRCUIT DIAGNOSIS >

[ICC]

## DTC/CIRCUIT DIAGNOSIS

### C1A00 CONTROL UNIT

#### DTC Description

INFOID:0000000011952961

#### DTC DETECTION LOGIC

DTC No.	CONSULT screen terms	DTC detection condition	
		Diagnosis condition	When ignition switch is ON.
C1A00	CONTROL UNIT (Control unit malfunction)	Signal (terminal)	—
		Threshold	ICC sensor CAN failure
		Diagnosis delay time	—

#### POSSIBLE CAUSE

ICC sensor

#### FAIL-SAFE

The following systems are canceled:

- Intelligent Cruise Control
- Forward Emergency Braking (FEB)
- Predictive Forward Collision Warning (PFCW)

#### DTC CONFIRMATION PROCEDURE

##### 1. PERFORM DTC CONFIRMATION PROCEDURE

1. Start the engine.
2. Perform "All DTC Reading" with CONSULT.
3. Check if the "C1A00" is detected as the current malfunction in "Self Diagnostic Result" mode of "LASER/RADAR".

Is "C1A00" detected as the current malfunction?

- YES >> Refer to [CCS-70. "Diagnosis Procedure"](#).
- NO-1 >> To check malfunction symptom before repair: Refer to [GI-41. "Intermittent Incident"](#).
- NO-2 >> Confirmation after repair: Inspection End.

#### Diagnosis Procedure

INFOID:0000000011952962

##### 1. CHECK SELF DIAGNOSTIC RESULT

Check if any DTC other than "C1A00" is detected in "Self Diagnostic Result" mode of "LASER/RADAR".

Is any DTC detected?

- YES >> Perform diagnosis on the detected DTC and repair or replace the malfunctioning parts. Refer to [CCS-46. "DTC Index"](#).
- NO >> Replace the ICC sensor. Refer to [CCS-136. "Removal and Installation"](#).

# C1A01 POWER SUPPLY CIRCUIT 1, C1A02 POWER SUPPLY CIRCUIT 2

< DTC/CIRCUIT DIAGNOSIS >

[ICC]

## C1A01 POWER SUPPLY CIRCUIT 1, C1A02 POWER SUPPLY CIRCUIT 2

### DTC Description

INFOID:0000000011952963

### DTC DETECTION LOGIC

DTC No.	CONSULT screen terms	DTC detection condition	
C1A01	POWER SUPPLY CIR (Power supply circuit)	Diagnosis condition	When ignition switch is ON.
		Signal (terminal)	—
		Threshold	The battery voltage sent to ICC sensor remains less than 8.6 V.
		Diagnosis delay time	—
C1A02	POWER SUPPLY CIR 2 (Power supply circuit 2)	Diagnosis condition	When Ignition switch is ON.
		Signal (terminal)	—
		Threshold	The battery voltage sent to ICC sensor remains more than 19.3 V.
		Diagnosis delay time	—

### POSSIBLE CAUSE

- Connector, harness or fuse
- ICC sensor

### FAIL-SAFE

The following systems are canceled:

- Intelligent Cruise Control
- Forward Emergency Braking (FEB)
- Predictive Forward Collision Warning (PFCW)

### DTC CONFIRMATION PROCEDURE

#### 1.PERFORM DTC CONFIRMATION PROCEDURE

1. Start the engine.
2. Turn the MAIN switch of ICC system ON.
3. Perform "All DTC Reading" with CONSULT.
4. Check if the "C1A01" or "C1A02" is detected as the current malfunction in "Self Diagnostic Result" mode of "LASER/RADAR".

Is "C1A01" or "C1A02" detected as the current malfunction?

- YES >> Refer to [CCS-71, "Diagnosis Procedure"](#).  
NO-1 >> To check malfunction symptom before repair: Refer to [GI-41, "Intermittent Incident"](#).  
NO-2 >> Confirmation after repair: Inspection End.

### Diagnosis Procedure

INFOID:0000000011952964

#### 1.CHECK ICC SENSOR POWER SUPPLY AND GROUND CIRCUIT

Check power supply and ground circuit of ICC sensor. Refer to [CCS-113, "ICC SENSOR : Diagnosis Procedure"](#).

Is the inspection result normal?

- YES >> Replace the ICC sensor. Refer to [CCS-136, "Removal and Installation"](#).  
NO >> Repair or replace the malfunctioning parts.

# C1A03 VEHICLE SPEED SENSOR

< DTC/CIRCUIT DIAGNOSIS >

[ICC]

## C1A03 VEHICLE SPEED SENSOR

### DTC Description

INFOID:000000011952965

### DTC DETECTION LOGIC

DTC No.	CONSULT screen terms	DTC detection condition	
C1A03	VHCL SPEED SE CIRC (Vehicle speed sensor circuit)	Diagnosis condition	When ignition switch is ON.
		Signal (terminal)	—
		Threshold	<ul style="list-style-type: none"><li>If the vehicle speed signal (wheel speed) from ABS actuator and electric unit (control unit) and the CVT vehicle speed sensor signal (output shaft revolution signal) from TCM, received by the ICC sensor unit via CAN communication, are inconsistent</li><li>If tire size is not correct</li></ul>
		Diagnosis delay time	—

### POSSIBLE CAUSE

- Wheel speed sensor
- ABS actuator and electric unit (control unit)
- Vehicle speed sensor CVT (output speed sensor)
- TCM
- ICC sensor
- Tire

### FAIL-SAFE

The following systems are canceled:

- Intelligent Cruise Control
- Forward Emergency Braking (FEB)
- Predictive Forward Collision Warning (PFCW)
- Blind Spot Warning (BSW)
- Back-up Collision Intervention (BCI)

### DTC CONFIRMATION PROCEDURE

#### 1. CHECK DTC PRIORITY

If DTC “C1A03” is displayed with DTC “U1000” or “C1A04”, first diagnose the DTC “U1000” or “C1A04”.

#### Is applicable DTC detected?

- YES >> Perform diagnosis of applicable DTC.
- U1000: Refer to [CCS-111, "DTC Logic"](#).
  - C1A04: Refer to [CCS-74, "DTC Description"](#).

No-1 >> Check the tire size.

NO-2 >> GO TO 2.

#### 2. PERFORM DTC CONFIRMATION PROCEDURE

1. Start the engine.
2. Turn the MAIN switch of ICC system ON.
3. Drive the vehicle at 30 km/h (19 MPH) or more.  
**CAUTION:**  
**Always drive safely.**
4. Stop the vehicle.
5. Perform “All DTC Reading” with CONSULT.
6. Check if the “C1A03” is detected as the current malfunction in “Self Diagnostic Result” mode of “LASER/RADAR”.

#### Is “C1A03” detected as the current malfunction?

- YES >> Refer to [CCS-73, "Diagnosis Procedure"](#).
- NO-1 >> To check malfunction symptom before repair: Refer to [GI-41, "Intermittent Incident"](#).
- NO-2 >> Confirmation after repair: Inspection End.



# C1A03 VEHICLE SPEED SENSOR

< DTC/CIRCUIT DIAGNOSIS >

[ICC]

## Diagnosis Procedure

INFOID:000000011952966

### 1. CHECK DTC PRIORITY

If DTC "C1A03" is displayed with DTC "U1000" or "C1A04", first diagnose the DTC "U1000" or "C1A04".

Is applicable DTC detected?

- YES >> Perform diagnosis of applicable DTC.
- U1000: Refer to [CCS-111, "DTC Logic"](#).
  - C1A04: Refer to [CCS-74, "DTC Description"](#).
- NO >> GO TO 2.

### 2. CHECK DATA MONITOR

1. Start the engine.
2. Drive the vehicle.
3. Check that the value of "VHCL SPD AT" is almost the same as the value of "VHCL SPEED SE" in "Data Monitor" mode of "LASER/RADAR".

#### **CAUTION:**

**Be careful of the vehicle speed.**

Is the inspection result normal?

- YES >> Replace the ADAS control unit. Refer to [DAS-80, "Removal and Installation"](#).
- NO >> GO TO 3.

### 3. CHECK TCM SELF-DIAGNOSIS RESULTS

1. Perform "All DTC Reading".
2. Check if any DTC is detected in "Self Diagnostic Result" mode of "TRANSMISSION".

Is any DTC detected?

- YES >> Perform diagnosis on the detected DTC and repair or replace the malfunctioning parts. Refer to [TM-58, "DTC Index"](#).
- NO >> GO TO 4.

### 4. CHECK ABS ACTUATOR AND ELECTRIC UNIT (CONTROL UNIT) SELF-DIAGNOSIS RESULTS

Check if any DTC is detected in "Self Diagnostic Result" mode of "ABS".

Is any DTC detected?

- YES >> Perform diagnosis on the detected DTC and repair or replace the malfunctioning parts. Refer to [BRC-227, "DTC Index"](#).
- NO >> Replace the ICC sensor. Refer to [CCS-136, "Removal and Installation"](#).

A  
B  
C  
D  
E  
F  
G  
H  
I  
J  
K  
L  
M  
N  
P

CCS

# C1A04 ABS/TCS/VDC SYSTEM

< DTC/CIRCUIT DIAGNOSIS >

[ICC]

## C1A04 ABS/TCS/VDC SYSTEM

### DTC Description

INFOID:000000011952967

### DTC DETECTION LOGIC

DTC No.	CONSULT screen terms	DTC detection condition	
C1A04	ABS/TCS/VDC CIRC (ABS/TCS/VDC circuit)	Diagnosis condition	When ignition switch is ON.
		Signal (terminal)	—
		Threshold	If a malfunction occurs in the VDC/TCS/ABS system
		Diagnosis delay time	—

### POSSIBLE CAUSE

ABS actuator and electric unit (control unit)

### FAIL-SAFE

The following systems are canceled:

- Intelligent Cruise Control
- Forward Emergency Braking (FEB)
- Predictive Forward Collision Warning (PFCW)

### DTC CONFIRMATION PROCEDURE

#### 1. CHECK DTC PRIORITY

If DTC "C1A04" is displayed with DTC "U1000", first diagnose the DTC "U1000".

Is applicable DTC detected?

YES >> Perform diagnosis of applicable DTC. Refer to [CCS-111, "Diagnosis Procedure"](#).

NO >> GO TO 2.

#### 2. PERFORM DTC CONFIRMATION PROCEDURE

1. Start the engine.
2. Turn the MAIN switch of ICC system ON.
3. Perform "All DTC Reading" with CONSULT.
4. Check if the "C1A04" is detected as the current malfunction in "Self Diagnostic Result" mode of "LASER/RADAR".

Is "C1A04" detected as the current malfunction?

YES >> Refer to [CCS-74, "Diagnosis Procedure"](#).

NO-1 >> To check malfunction symptom before repair: Refer to [GI-41, "Intermittent Incident"](#).

NO-2 >> Confirmation after repair: Inspection End.

### Diagnosis Procedure

INFOID:000000011952968

#### 1. CHECK DTC PRIORITY

If DTC "C1A04" is displayed with DTC "U1000", first diagnose the DTC "U1000".

Is applicable DTC detected?

YES >> Perform diagnosis of applicable. Refer to [CCS-111, "DTC Logic"](#).

NO >> GO TO 2.

#### 2. CHECK ABS ACTUATOR AND ELECTRIC UNIT (CONTROL UNIT) SELF-DIAGNOSIS RESULTS

Check if any DTC is detected in "Self Diagnostic Result" mode of "ABS".

Is any DTC detected?

YES >> Perform diagnosis on the detected DTC and repair or replace the malfunctioning parts. Refer to [BRC-227, "DTC Index"](#).

NO >> Replace the ADAS control unit. Refer to [DAS-80, "Removal and Installation"](#).

# C1A05 BRAKE SW/STOP LAMP SW

< DTC/CIRCUIT DIAGNOSIS >

[ICC]

## C1A05 BRAKE SW/STOP LAMP SW

### DTC Description

INFOID:000000011952969

### DTC DETECTION LOGIC

DTC No.	CONSULT screen terms	DTC detection condition	
C1A05	BRAKE SW/STOP L SW (Brake switch/Stop lamp switch)	Diagnosis condition	When ignition switch is ON.
		Signal (terminal)	—
		Threshold	A mismatch between a stop lamp switch signal and a brake pedal position switch signal received from ECM and a stop lamp signal received from the ABS actuator and electric unit (control unit) continues for 60 seconds or more when vehicle speed is approximately 40 km/h (65 MPH) or more.
		Diagnosis delay time	—

### POSSIBLE CAUSE

- Stop lamp switch circuit
- Brake pedal position switch circuit
- Stop lamp switch
- Brake pedal position switch
- Incorrect stop lamp switch installation
- Incorrect brake pedal position switch installation
- ECM
- ABS actuator and electric unit (control unit)

### FAIL-SAFE

The following systems are canceled:

- Intelligent Cruise Control
- Forward Emergency Braking (FEB)

### DTC CONFIRMATION PROCEDURE

#### 1. CHECK DTC PRIORITY

If DTC "C1A05" is displayed with DTC "U1000", first diagnose the DTC "U1000".

Is applicable DTC detected?

- YES >> Perform diagnosis of applicable DTC. Refer to [CCS-111, "DTC Logic"](#).  
NO >> GO TO 2.

#### 2. PERFORM DTC CONFIRMATION PROCEDURE

##### CONSULT

1. Start the engine.
2. Turn the MAIN switch of ICC system ON.
3. Select "Self Diagnostic Result" mode of "LASER/RADAR".
4. Check if the "C1A05" is detected as the current malfunction in "Self Diagnostic Result" mode of "LASER/RADAR".

Is "C1A05" detected as the current malfunction?

- YES >> Refer to [CCS-75, "Diagnosis Procedure"](#).  
NO-1 >> To check malfunction symptom before repair: Refer to [GI-41, "Intermittent Incident"](#).  
NO-2 >> Confirmation after repair: Inspection End.

### Diagnosis Procedure

INFOID:000000011952970

Regarding Wiring Diagram Information, refer to [CCS-49, "Wiring Diagram"](#).

#### 1. CHECK DTC PRIORITY

If DTC "C1A05" is displayed with DTC "U1000", first diagnose the DTC "U1000".

Is applicable DTC detected?

A  
B  
C  
D  
E  
F  
G  
H  
I  
J  
K  
L  
M  
N  
P

CCS

# C1A05 BRAKE SW/STOP LAMP SW

[ICC]

< DTC/CIRCUIT DIAGNOSIS >

- YES >> Perform diagnosis of applicable DTC. Refer to [CCS-75, "DTC Description"](#).  
NO >> GO TO 2.

## 2.CHECK STOP LAMP SWITCH AND BRAKE PEDAL POSITION SWITCH

Check that "STOP LAMP SW" and "BRAKE SW" operate normally in "Data Monitor" mode of "LASER/RADAR".

Is the inspection result normal?

- YES >> GO TO 3.  
NO-1 >> When "BRAKE SW" operation is malfunctioning: GO TO 4.  
NO-2 >> When "STOP LAMP SW" operation is malfunctioning: GO TO 9.

## 3.CHECK STOP LAMP SWITCH

Check that "STOP LAMP SW" operates normally in "Data Monitor" mode of "ABS".

Is the inspection result normal?

- YES >> GO TO 14.  
NO >> GO TO 9.

## 4.CHECK BRAKE PEDAL POSITION SWITCH INSTALLATION

1. Turn ignition switch OFF.
2. Check brake pedal position switch for correct installation. Refer to [BR-12, "Adjustment"](#).

Is the inspection result normal?

- YES >> GO TO 5.  
NO >> Adjust brake pedal position switch installation. Refer to [BR-12, "Adjustment"](#).

## 5.BRAKE PEDAL POSITION SWITCH INSPECTION

1. Disconnect brake pedal position switch connector.
2. Check brake pedal position switch. Refer to [CCS-78, "Component Inspection \(Brake Pedal Position Switch\)"](#).

Is the inspection result normal?

- YES >> GO TO 6.  
NO >> Replace brake pedal position switch.

## 6.CHECK BRAKE PEDAL POSITION SWITCH POWER SUPPLY CIRCUIT

1. Turn the ignition switch ON.
2. Check voltage between brake pedal position switch harness connector and ground.

(+)		(-)	Voltage (Approx.)
Brake pedal position switch		Ground	Battery voltage
Connector	Terminal		
E37	1		

Is the inspection result normal?

- YES >> GO TO 7.  
NO >> Repair the harnesses or connectors.

## 7.CHECK HARNESS BETWEEN BRAKE PEDAL POSITION SWITCH AND ECM

1. Turn ignition switch OFF
2. Disconnect ECM connector.
3. Check for continuity between brake pedal position switch harness connector and ECM harness connector.

Brake pedal position switch		ECM		Continuity
Connector	Terminal	Connector	Terminal	
E37	2	E10	140	Yes

4. Check for continuity between brake pedal position switch harness connector and ground.

# C1A05 BRAKE SW/STOP LAMP SW

< DTC/CIRCUIT DIAGNOSIS >

[ICC]

Brake pedal position switch		Ground	Continuity
Connector	Terminal		
E37	2		No

Is the inspection result normal?

- YES >> GO TO 8.
- NO >> Repair the harnesses or connectors.

## 8. PERFORM SELF DIAGNOSTIC RESULTS OF ECM

### CONSULT

1. Connect all connectors if the connectors were disconnected.
2. Turn ignition switch ON.
3. Select "Self Diagnostic Result" mode of "ENGINE".
4. Check if any DTC is detected in "Self Diagnostic Result" mode of "ENGINE". Refer to [EC-107, "DTC Index"](#).

Is any DTC detected?

- YES >> Repair or replace the malfunctioning parts identified by the self-diagnosis result.
- NO >> Replace the ADAS control unit. Refer to [DAS-80, "Removal and Installation"](#).

## 9. CHECK STOP LAMP SWITCH INSTALLATION

1. Turn ignition switch OFF.
2. Check stop lamp switch for correct installation. Refer to [BR-12, "Adjustment"](#).

Is the inspection result normal?

- YES >> GO TO 10.
- NO >> Adjust stop lamp switch installation. Refer to [BR-12, "Adjustment"](#).

## 10. STOP LAMP SWITCH INSPECTION

1. Disconnect stop lamp switch connector.
2. Check stop lamp switch. Refer to [CCS-78, "Component Inspection \(Stop Lamp Switch\)"](#).

Is the inspection result normal?

- YES >> GO TO 11.
- NO >> Replace stop lamp switch.

## 11. CHECK STOP LAMP SWITCH POWER SUPPLY CIRCUIT

1. Check voltage between stop lamp switch harness connector and ground.

(+)		(-)	Voltage (Approx.)
Stop lamp switch			Ground
Connector	Terminal		
E38	4		

Is the inspection result normal?

- YES >> GO TO 12.
- NO >> Repair the harnesses or connectors.

## 12. CHECK HARNESS BETWEEN STOP LAMP SWITCH AND ABS ACTUATOR AND ELECTRIC UNIT (CONTROL UNIT)

1. Disconnect ABS actuator and electric unit (control unit) connector and resistor.
2. Check for continuity between stop lamp switch harness connector and ABS actuator and electric unit (control unit) harness connector.

Stop lamp switch		ABS actuator and electric unit (control unit)		Continuity
Connector	Terminal	Connector	Terminal	
E38	3	E53	7	Yes

## C1A05 BRAKE SW/STOP LAMP SW

< DTC/CIRCUIT DIAGNOSIS >

[ICC]

3. Check for continuity between stop lamp switch harness connector and ground.

Stop lamp switch		Ground	Continuity
Connector	Terminal		
E38	3		No

Is the inspection result normal?

YES >> GO TO 13.

NO >> Repair the harnesses or connectors.

### 13. PERFORM SELF DIAGNOSTIC RESULT OF ECM

1. Connect all connectors if the connectors are disconnected.
2. Turn ignition switch ON.
3. Perform "All DTC Reading".
4. Check if any DTC is detected in "Self Diagnostic Result" mode of "ENGINE". Refer to [EC-107, "DTC Index"](#).

Is any DTC detected?

YES >> Repair or replace the malfunctioning parts identified by the self-diagnosis result.

NO >> GO TO 14.

### 14. PERFORM SELF-DIAGNOSIS OF ABS ACTUATOR AND ELECTRIC UNIT (CONTROL UNIT)

Check if any DTC is detected in "Self Diagnostic Result" mode of "ABS". Refer to [BRC-227, "DTC Index"](#).

Is any DTC detected?

YES >> Repair or replace the malfunctioning parts identified by the self-diagnosis result.

NO >> Repair the ICC sensor. Refer to [DAS-80, "Removal and Installation"](#).

## Component Inspection (Brake Pedal Position Switch)

INFOID:000000011952971

### 1. CHECK BRAKE PEDAL POSITION SWITCH

Check for continuity between brake pedal position switch terminals.

Terminals		Condition	Continuity
1	2	When brake pedal is depressed	No
		When brake pedal is released	Yes

Is the inspection result normal?

YES >> Inspection End.

NO >> Replace brake pedal position switch.

## Component Inspection (Stop Lamp Switch)

INFOID:000000011952972

### 1. CHECK STOP LAMP SWITCH

Check for continuity between stop lamp switch terminals.

Terminals		Condition	Continuity
1	2	When brake pedal is depressed	Yes
		When brake pedal is released	No
3	4	When brake pedal is depressed	Yes
		When brake pedal is released	No

Is the inspection result normal?

YES >> Inspection End.

NO >> Replace stop lamp switch.

C1A06 OPERATION SW

DTC Description

INFOID:000000011952973

DTC DETECTION LOGIC

DTC No.	CONSULT screen terms	DTC detection condition	
C1A06	OPERATION SW CIRC (Operation switch circuit)	Diagnosis condition	When ignition switch is ON.
		Signal (terminal)	—
		Threshold	<ul style="list-style-type: none"> <li>Any switch of the ICC steering switch is detected as "ON" continuously for 60 seconds.</li> <li>An ON/OFF state judgment of the ICC differs between ECM and ICC sensor, and the state continues for 2 seconds or more.</li> </ul>
		Diagnosis delay time	—

POSSIBLE CAUSE

- ICC steering switch circuit
- ICC steering switch
- ECM

FAIL-SAFE

- The following systems are canceled:
- Intelligent Cruise Control system is canceled

DTC CONFIRMATION PROCEDURE

1. CHECK DTC PRIORITY

If DTC "C1A06" is displayed with DTC "U1000", first diagnose the DTC "U1000".

Is applicable DTC detected?

- YES >> Perform diagnosis of applicable DTC. Refer to [CCS-111, "DTC Logic"](#).
- NO >> GO TO 2.

2. PERFORM DTC CONFIRMATION PROCEDURE

 CONSULT

1. Start the engine.
2. Wait for approximately 5 minutes after turning the MAIN switch of ICC system ON.
3. Select "Self Diagnostic Result" mode of "LASER/RADAR".
4. Check if the "C1A06" is detected as the current malfunction in "Self Diagnostic Result" mode of "LASER/RADAR".

Is "C1A06" detected as the current malfunction?

- YES >> Refer to [CCS-79, "Diagnosis Procedure"](#).
- NO-1 >> To check malfunction symptom before repair: Refer to [GI-41, "Intermittent Incident"](#).
- NO-2 >> Confirmation after repair: Inspection End.

Diagnosis Procedure

INFOID:000000011952974

1. CHECK DTC PRIORITY

If DTC "C1A06" is displayed with DTC "U1000", first diagnose the DTC "U1000".

Is applicable DTC detected?

- YES >> Perform diagnosis of applicable DTC. Refer to [CCS-111, "DTC Logic"](#).
- NO >> GO TO 2.

2. CHECK ICC STEERING SWITCH

1. Turn the ignition switch OFF.
2. Disconnect the ICC steering switch connector.
3. Check the ICC steering switch. Refer to [CCS-80, "Component Inspection"](#).

Is the inspection result normal?

A  
B  
C  
D  
E  
F  
G  
H  
I  
J  
K  
L  
M  
N  
P



# C1A06 OPERATION SW

[ICC]

## < DTC/CIRCUIT DIAGNOSIS >

- YES >> GO TO 3.  
NO >> Replace the ICC steering switch.

### 3.CHECK HARNESS BETWEEN SPIRAL CABLE AND ECM

1. Disconnect the ECM connector.
2. Check for continuity between the spiral cable harness connector and ECM harness connector.

Spiral cable		ECM		Continuity
Connector	Terminal	Connector	Terminal	
M30	10	E10	134	Yes
	7		135	

3. Check for continuity between spiral cable harness connector and ground.

Spiral cable		Ground	Continuity
Connector	Terminal		
M30	10		No
	7		

#### Is the inspection result normal?

- YES >> GO TO 4.  
NO >> Repair the harnesses or connectors.

### 4.CHECK SPIRAL CABLE

Check for continuity between spiral cable terminals.

Spiral cable		Continuity
Terminals		
10	15	Yes
7	18	

#### Is the inspection result normal?

- YES >> GO TO 5.  
NO >> Replace the spiral cable.

### 5.PERFORM SELF DIAGNOSTIC RESULT OF ECM

#### Ⓟ CONSULT

1. Connect the connectors of ICC steering switch and ECM connector.
2. Turn the ignition switch ON.
3. Select "Self Diagnostic Result" mode of "ENGINE".
4. Check if any DTC is detected in "Self Diagnostic Result" mode of "ENGINE".

#### Is any DTC detected?

- YES >> Select "Self Diagnostic Result" on the detected DTC and repair or replace the malfunctioning parts. Refer to [EC-107, "DTC Index"](#).  
NO >> Replace the ICC sensor. Refer to [DAS-80, "Removal and Installation"](#)

## Component Inspection

INFOID:000000011952975

### 1.CHECK ICC STEERING SWITCH

Check resistance between ICC steering switch terminals.



# C1A06 OPERATION SW

< DTC/CIRCUIT DIAGNOSIS >

[ICC]

Terminals		Switch operation	Approx. Resistance [ $\Omega$ ]
15	18	When pressing MAIN switch	1
		When pressing CANCEL switch	309
		When pressing DISTANCE switch	741
		When pressing SET/COAST switch	1406
		When pressing RESUME/ACCELERATE switch	2586
		When all switches are not pressed	5456

Is the inspection result normal?

YES >> Inspection End.

NO >> Replace the ICC steering switch.

A  
B  
C  
D  
E  
F  
G  
H  
I  
J  
K  
L  
M  
N  
P



# C1A12 LASER BEAM OFF CENTER

< DTC/CIRCUIT DIAGNOSIS >

[ICC]

## C1A12 LASER BEAM OFF CENTER

### DTC Description

INFOID:000000011952976

### DTC DETECTION LOGIC

DTC No.	CONSULT screen terms	DTC detection condition	
C1A12	LASER BEAM OFFCNTR	Diagnosis condition	When ignition switch is ON.
		Signal (terminal)	—
		Threshold	Radar of ICC sensor is off the aiming point.
		Diagnosis delay time	—

### POSSIBLE CAUSE

- ICC sensor

### FAIL-SAFE

- Intelligent Cruise Control is canceled

### Diagnosis Procedure

INFOID:000000011952977

## 1.PERFORM ICC SENSOR SELF DIAGNOSTIC RESULT

### Ⓜ CONSULT

1. Select "Self Diagnostic Result" mode of "LASER/RADAR".
2. Check if the "C1A12" is detected as the current malfunction in "Self Diagnostic Result" mode of "LASER/RADAR".

#### Is "C1A12" detected?

- YES >> Refer to [CCS-82, "DTC Description"](#).  
NO >> GO TO 2.

## 2.VISUAL INSPECTION

1. Check ICC sensor and ICC sensor bracket for damage or looseness.

#### Does damage or looseness exist?

- YES >> 1. Repair or replace affected components. Refer to [CCS-136, "Removal and Installation"](#).  
2. Perform ICC sensor alignment. Refer to [CCS-59, "Description"](#).  
3. Perform action test. Refer to [CCS-66, "Description"](#).  
NO >> GO TO 3.

## 3.PERFORM ADAS CONTROL SELF DIAGNOSTIC RESULT

### Ⓜ CONSULT

Check if the "C1A12" is detected as the current malfunction in "Self Diagnostic Result" mode of "ICC/ADAS".

#### Is "C1A12" detected?

- YES >> Replace ICC sensor. Refer to [CCS-136, "Removal and Installation"](#).  
NO >> Inspection End.

# C1A13 STOP LAMP RELAY

< DTC/CIRCUIT DIAGNOSIS >

[ICC]

## C1A13 STOP LAMP RELAY

### DTC Description

INFOID:0000000011952978

### DTC DETECTION LOGIC

DTC No.	CONSULT screen terms	DTC detection condition	
C1A13	STOP LAMP RLY FIX (Stop lamp relay fix)	Diagnosis condition	When ignition switch is ON.
		Signal (terminal)	—
		Threshold	<ul style="list-style-type: none"> <li>• Stop lamp inactive state continues for 0.3 seconds or more despite the outputting of an ICC brake hold relay drive signal.</li> <li>• The stop lamp remains ON for 60 seconds or more under the following conditions:                             <ul style="list-style-type: none"> <li>- Driving at 40 km/h (25 MPH) or more</li> <li>- No stop lamp drive signal outputted from ADAS control unit</li> <li>- No brake operation</li> </ul> </li> </ul>
		Diagnosis delay time	—

### POSSIBLE CAUSE

- Stop lamp switch circuit
- Brake pedal position switch circuit
- ICC brake hold relay circuit
- Stop lamp switch
- Brake pedal position switch
- ICC brake hold relay
- Incorrect stop lamp switch installation
- Incorrect brake pedal position switch installation
- ECM
- ABS actuator and electric unit (control unit)

### FAIL-SAFE

The following systems are canceled:

- Intelligent Cruise Control
- Forward Emergency Braking (FEB)
- Predictive Forward Collision Warning (PFCW)

### DTC CONFIRMATION PROCEDURE

#### 1. CHECK DTC PRIORITY

If DTC "C1A13" is displayed with DTC "U1000", first diagnose the DTC "U1000".

Is applicable DTC detected?

- YES >> Perform diagnosis of applicable DTC. Refer to [CCS-111, "DTC Logic"](#).  
 NO >> GO TO 2.

#### 2. PERFORM DTC CONFIRMATION PROCEDURE (1)

##### Ⓜ CONSULT

1. Start the engine.
2. Select the "Active Test" mode "STOP LAMP".
3. Perform "All DTC Reading".
4. Check if the "C1A13" is detected as the current malfunction in the "Self Diagnostic Result" mode of "ICC/ADAS".

Is "C1A13" detected as the current malfunction?

- YES >> Refer to [DAS-44, "Diagnosis Procedure"](#).  
 NO >> GO TO 3.

#### 3. PERFORM DTC CONFIRMATION PROCEDURE (2)

##### Ⓜ CONSULT

A  
B  
C  
D  
E  
F  
G  
H  
I  
J  
K  
L  
M  
N  
P

CCS

## C1A13 STOP LAMP RELAY

< DTC/CIRCUIT DIAGNOSIS >

[ICC]

1. Drive the vehicle at a speed of 40 km/h (25 MPH) or more for approximately 20 seconds or more without the brake pedal depressed.

**CAUTION:**

**Always drive safely.**

**NOTE:**

If it is outside the above condition, repeat step 1.

2. Select "Self Diagnostic Result" mode of "ICC/ADAS".
3. Check if the "C1A13" is detected as the current malfunction in the "Self Diagnostic Result" mode of "ICC/ADAS".

Is "C1A13" detected as the current malfunction?

YES >> Refer to [DAS-44, "Diagnosis Procedure"](#).

NO-1 >> To check malfunction symptom before repair: Refer to [GI-41, "Intermittent Incident"](#).

NO-2 >> Confirmation after repair: Inspection End.

C1A14 ECM

DTC Description

INFOID:000000011952979

DTC DETECTION LOGIC

DTC No.	CONSULT screen terms	DTC detection condition	
C1A14	ECM CIRCUIT (ECM circuit)	Diagnosis condition	When ignition switch is ON.
		Signal (terminal)	—
		Threshold	If ECM is malfunctioning
		Diagnosis delay time	—

POSSIBLE CAUSE

- Accelerator pedal position sensor
- ECM
- ICC sensor

FAIL-SAFE

The following systems are canceled:

- Intelligent Cruise Control
- Forward Emergency Braking (FEB)
- Predictive Forward Collision Warning (PFCW)

DTC CONFIRMATION PROCEDURE

1. CHECK DTC PRIORITY

If DTC "C1A14" is displayed with DTC "U1000", first diagnose the DTC "U1000".

Is applicable DTC detected?

- YES >> Perform diagnosis of applicable DTC. Refer to [CCS-111, "DTC Logic"](#).
- NO >> GO TO 2.

2. PERFORM DTC CONFIRMATION PROCEDURE

1. Start the engine.
2. Operate the ICC system and drive.  
**CAUTION:**  
**Always drive safely.**
3. Stop the vehicle.
4. Select "Self Diagnostic Result" mode of "LASER/RADAR".
5. Check if the "C1A14" is detected as the current malfunction in "Self Diagnostic Result" mode of "LASER/RADAR".

Is "C1A14" detected as the current malfunction?

- YES >> Refer to [CCS-85, "Diagnosis Procedure"](#).
- NO-1 >> To check malfunction symptom before repair: Refer to [GI-41, "Intermittent Incident"](#).
- NO-2 >> Confirmation after repair: Inspection End.

Diagnosis Procedure

INFOID:000000011952980

1. CHECK DTC PRIORITY

If DTC "C1A14" is displayed with DTC "U1000", first diagnose the DTC "U1000".

Is applicable DTC detected?

- YES >> Perform diagnosis of applicable DTC. Refer to [CCS-111, "DTC Logic"](#).
- NO >> GO TO 2.

2. CHECK SELF DIAGNOSTIC RESULT

Check if "U1000" is detected other than "C1A14" in "Self Diagnostic Result" mode of "LASER/RADAR".

Is "U1000" detected?

A  
B  
C  
D  
E  
F  
G  
H  
I  
J  
K  
L  
M  
N



P

## C1A14 ECM

### < DTC/CIRCUIT DIAGNOSIS >

[ICC]

- YES >> Perform the CAN communication system inspection. Repair or replace the malfunctioning parts.  
Refer to [CCS-111, "DTC Logic"](#).
- NO >> GO TO 3.

### 3.PERFORM SELF DIAGNOSTIC RESULT OF ECM

#### CONSULT

Select "Self Diagnostic Result" mode of "ENGINE".

#### Is any DTC detected?

- YES >> Perform diagnosis on the detected DTC and repair or replace the malfunctioning parts. Refer to [EC-107, "DTC Index"](#).
- NO >> Replace the ICC sensor. Refer to [CCS-136, "Exploded View"](#).

# C1A15 GEAR POSITION

< DTC/CIRCUIT DIAGNOSIS >

[ICC]

## C1A15 GEAR POSITION

### DTC Description

INFOID:0000000011952981

ADAS control unit judges the gear position based on the following signals:

- Current gear position signal transmitted from TCM via CAN communication.
- Value of gear ratio calculated from input speed signal transmitted from TCM via CAN communication.
- Value of gear ratio calculated from the vehicle speed signal transmitted from ABS actuator and electric unit (control unit) via CAN communication.

### DTC Logic

INFOID:0000000011952982

### DTC DETECTION LOGIC

DTC No.	CONSULT screen terms	DTC detection condition	
C1A15	GEAR POSITION (Gear position)	Diagnosis condition	When ignition switch is ON.
		Signal (terminal)	—
		Threshold	A mismatch between a current gear position signal transmitted from TCM via CAN communication and a gear position calculated by the ICC sensor continues for approximately 11 minutes or more.
		Diagnosis delay time	—

### POSSIBLE CAUSE

- Input speed sensor
- Vehicle speed sensor CVT (output speed sensor)
- TCM

### FAIL-SAFE

The following systems are canceled:

- Intelligent Cruise Control
- Forward Emergency Braking (FEB)
- Predictive Forward Collision Warning (PFCW)

### DTC CONFIRMATION PROCEDURE

#### 1. CHECK DTC PRIORITY

If DTC "C1A15" is displayed with DTC "U1000", "C1A03", or "C1A04", first diagnose the DTC "U1000", "C1A03", or "C1A04".

#### Is applicable DTC detected?

- YES >> Perform diagnosis of applicable DTC.
- U1000: Refer to [CCS-111, "DTC Logic"](#).
  - C1A03: Refer to [CCS-72, "DTC Description"](#).
  - C1A04: Refer to [CCS-74, "DTC Description"](#).

NO >> GO TO 2.

#### 2. PERFORM DTC CONFIRMATION PROCEDURE

##### CONSULT

1. Start the engine.
2. Turn the MAIN switch of ICC system ON.
3. Drive the vehicle at 10 km/h (6 MPH) or more for approximately 15 minutes or more.

#### **CAUTION:**

**Always drive safely.**

4. Stop the vehicle.
5. Select "Self Diagnostic Result" mode of "LASER/RADAR".
6. Check if "C1A15" is detected as the current malfunction in the "Self Diagnostic Result" mode of "LASER/RADAR".

#### Is "C1A15" detected as the current malfunction?

- YES >> Refer to [CCS-88, "Diagnosis Procedure"](#).

A  
B  
C  
D  
E  
F  
G  
H  
I  
J  
K  
L  
M  
N

CCS

P

# C1A15 GEAR POSITION

[ICC]

< DTC/CIRCUIT DIAGNOSIS >

- NO-1 >> To check malfunction symptom before repair: Refer to [GI-41, "Intermittent Incident"](#).  
NO-2 >> Confirmation after repair: Inspection End.

## Diagnosis Procedure

INFOID:000000011952983

### 1. CHECK DTC PRIORITY

If DTC "C1A15" is displayed with DTC "U1000" or "C1A03", or "C1A04", first diagnose the DTC "U1000", "C1A03", or "C1A04".

Is applicable DTC detected?

- YES >> Perform diagnosis of applicable DTC.
- U1000: Refer to [CCS-111, "DTC Logic"](#).
  - C1A03: Refer to [CCS-72, "DTC Description"](#).
  - C1A04: Refer to [CCS-74, "DTC Description"](#).
- NO >> GO TO 2.

### 2. CHECK VEHICLE SPEED SIGNAL

Ⓜ CONSULT

Check that "VHCL SPEED SE" operates normally in "Data Monitor" mode of "LASER/RADAR".

**CAUTION:**

**Be careful of the vehicle speed.**

Is the inspection result normal?

- YES >> GO TO 3.  
NO >> GO TO 6.

### 3. CHECK GEAR POSITION SIGNAL

Ⓜ CONSULT

Check that "GEAR" operates normally in "Data Monitor" mode of "TRANSMISSION".

Is the inspection result normal?

- YES >> GO TO 4.  
NO >> GO TO 5.

### 4. CHECK INPUT SPEED SENSOR SIGNAL

Ⓜ CONSULT

Check that "INPUT SPEED" operates normally in "Data Monitor" mode of "TRANSMISSION".

Is the inspection result normal?

- YES >> Replace the ADAS control unit. Refer to [DAS-80, "Removal and Installation"](#).  
NO >> GO TO 5.

### 5. CHECK TCM SELF DIAGNOSTIC RESULT

Ⓜ CONSULT

1. Select "Self Diagnostic Result" mode of "TRANSMISSION".
2. Check if any DTC is detected in "Self Diagnostic Result" mode of "TRANSMISSION".

Is any DTC detected?

- YES >> Perform diagnosis on the detected DTC and repair or replace the malfunctioning parts. Refer to [TM-58, "DTC Index"](#).  
NO >> Replace the ADAS control unit. Refer to [DAS-80, "Removal and Installation"](#).

### 6. CHECK ABS ACTUATOR AND ELECTRIC UNIT (CONTROL UNIT) SELF DIAGNOSTIC RESULT

Ⓜ CONSULT

1. Select "Self Diagnostic Result" mode of "ABS".
2. Check if any DTC is detected in "Self Diagnostic Result" mode of "ABS".

Is any DTC detected?

- YES >> Perform diagnosis on the detected DTC and repair or replace the malfunctioning parts. Refer to [BRC-227, "DTC Index"](#).  
NO >> Replace the ICC sensor. Refer to [DAS-80, "Removal and Installation"](#).



# C1A16 RADAR BLOCKED OR STAINED

< DTC/CIRCUIT DIAGNOSIS >

[ICC]

## C1A16 RADAR BLOCKED OR STAINED

### DTC Description

INFOID:0000000011952984

### DTC DETECTION LOGIC

DTC No.	CONSULT screen terms	DTC detection condition	
C1A16	RADAR BLOCKED	Diagnosis condition	When ignition switch is ON.
		Signal (terminal)	—
		Threshold	If any stain occurs to distance sensor body window.
		Diagnosis delay time	—

#### NOTE:

DTC "C1A16" may be detected under the following conditions. (Explain to the customer about the difference between the contamination detection function and the indication when the malfunction is detected and tell them, "This is not a malfunction")

- When contamination or foreign materials adhere to the ICC sensor area.
- When driving while it is snowing or when frost forms on the ICC sensor area.
- When ICC sensor area is temporarily fogged.

#### POSSIBLE CAUSE

- Stain or foreign material deposited on ICC sensor
- Cracked or scratched ICC sensor

#### FAIL-SAFE

- Intelligent Cruise Control system is canceled

### Diagnosis Procedure

INFOID:0000000011952985

#### NOTE:

After ICC sensor alignment is performed, the vehicle must be driven at a speed of 4.5 MPH (7.2 km/h) or more for a minimum of 2 minutes before DTC C1A16 can be cleared.

#### 1.VISUAL CHECK 1

Check for contamination and foreign matter on the ICC sensor area of the front bumper.

##### Does contamination or foreign material exist?

- YES >> Clean the contamination and foreign material on the ICC sensor area of the front bumper.  
NO >> GO TO 2.

#### 2.VISUAL CHECK 2

Check ICC sensor for contamination and foreign materials.

##### Does contamination or foreign material exist?

- YES >> Clean the contamination and foreign material from the ICC sensor.  
NO >> GO TO 3.

#### 3.VISUAL CHECK 3

Check ICC sensor and ICC sensor bracket for damage or looseness.

##### Does damage or looseness exist?

- YES >> 1. Repair or replace effected components. Refer to [CCS-136, "Removal and Installation"](#).  
2. Perform ICC sensor alignment. Refer to [CCS-59, "Description"](#).  
3. Perform action test. Refer to [CCS-59, "Description"](#).  
NO >> GO TO 4.

#### 4.INTERVIEW

1. Ask if there is any trace of contamination or foreign materials adhering to the ICC sensor area.
2. Ask if the ICC sensor area was frosted during driving or if vehicle was driven in snow.
3. Ask if ICC sensor area was temporarily fogged. (Windshield glass may also tend to fog, etc.)

Are any of the above conditions seen?

A  
B  
C  
D  
E  
F  
G  
H  
I  
J  
K  
L  
M  
N  
P

CCS

## C1A16 RADAR BLOCKED OR STAINED

[ICC]

### < DTC/CIRCUIT DIAGNOSIS >

---

- YES >> Explain to the customer about the difference between the contamination detection function and an actual malfunction. Inform them "this is not a malfunction".
- NO >> 1. Perform ICC sensor alignment. Refer to [CCS-59. "Description"](#).  
2. Perform action test. Refer to [CCS-66. "Description"](#).  
3. GO TO 5.

### 5.CHECK ICC SENSOR SELF DIAGNOSTIC RESULTS

---

#### Ⓟ CONSULT

Check if "C1A16" is detected as the current malfunction in "Self Diagnostic Result" mode of "LASER/RADAR".

#### Is "C1A16" detected?

- YES >> Replace ICC sensor. Refer to [CCS-136. "Removal and Installation"](#).
- NO >> Inspection End.

# C1A17 ICC SENSOR

< DTC/CIRCUIT DIAGNOSIS >

[ICC]

## C1A17 ICC SENSOR

### DTC Description

INFOID:0000000011952986

### DTC DETECTION LOGIC

DTC No.	CONSULT screen terms	DTC detection condition	
C1A17	ICC SENSOR MALF	Diagnosis condition	When ignition switch is ON.
		Signal (terminal)	—
		Threshold	If ICC sensor is malfunctioning
		Diagnosis delay time	—

#### NOTE:

If DTC “C1A17” is detected along with DTC “U1000”, first diagnose the DTC “U1000”. Refer to [CCS-111, "DTC Logic"](#).

### POSSIBLE CAUSE

ICC

### FAIL-SAFE

The following systems are canceled:

- Intelligent Cruise Control
- Forward Emergency Braking (FEB)
- Predictive Forward Collision Warning (PFCW)

### Diagnosis Procedure

INFOID:0000000011952987

## 1. CHECK ADAS CONTROL UNIT SELF DIAGNOSTIC RESULTS

#### CONSULT

1. Select “Self Diagnostic Result” mode of “ICC/ADAS”.
2. Check if “U1000” is detected along with “C1A17” in “Self Diagnostic Result” mode of “ICC/ADAS”.

#### Is “U1000” detected?

- YES >> Perform diagnosis on the detected DTC and repair or replace the malfunctioning parts. Refer to [CCS-111, "DTC Logic"](#).
- NO >> Replace ICC sensor. Refer to [CCS-136, "Removal and Installation"](#).

CCS

# C1A18 RADAR AIMING INCMP

< DTC/CIRCUIT DIAGNOSIS >

[ICC]

## C1A18 RADAR AIMING INCMP

### DTC Description

INFOID:000000011952988

### DTC DETECTION LOGIC

DTC No.	CONSULT screen terms	DTC detection condition	
C1A18	RADAR AIMING INCMP	Diagnosis condition	When ignition switch is ON.
		Signal (terminal)	—
		Threshold	The radar of the ICC sensor is not adjusted.
		Diagnosis delay time	—

### POSSIBLE CAUSE

- The adjustment of the radar is not yet performed.
- Interruption in radar adjustment

### FAIL-SAFE

The following systems are canceled:

- Intelligent Cruise Control
- Forward Emergency Braking (FEB)
- Predictive Forward Collision Warning (PFCW)

### DTC CONFIRMATION PROCEDURE

#### 1. PERFORM DTC CONFIRMATION PROCEDURE

##### CONSULT

1. Start the engine.
2. Turn the MAIN switch of ICC system ON.
3. Select "Self Diagnostic Result" mode of "LASER/RADAR".
4. Check if the "C1A18" is detected as the current malfunction in "Self Diagnostic Result" mode of "LASER/RADAR".

Is "C1A18" detected as the current malfunction?

- YES >> Refer to [CCS-92, "Diagnosis Procedure"](#).  
NO >> Inspection End.

### Diagnosis Procedure

INFOID:000000011952989

#### 1. ADJUST RADAR ALIGNMENT

##### CONSULT

1. Adjust the radar alignment. Refer to [CCS-59, "Description"](#).
2. Erase all "Self Diagnostic Result".
3. Perform "All DTC Reading".
4. Check if the "C1A18" is detected in "Self Diagnostic Result" mode of "LASER/RADAR".

Is "C1A18" detected?

- YES >> Replace the ICC sensor. Refer to [CCS-136, "Removal and Installation"](#).  
NO >> Inspection End.

# C1A21 UNIT HIGH TEMP

< DTC/CIRCUIT DIAGNOSIS >

[ICC]

## C1A21 UNIT HIGH TEMP

### DTC Description

INFOID:0000000011952990

### DTC DETECTION LOGIC

DTC No.	CONSULT screen terms	DTC detection condition	
C1A21	UNIT HIGH TEMP (Unit high temperature)	Diagnosis condition	When ignition switch is ON.
		Signal (terminal)	—
		Threshold	Temperature around ICC sensor is high.
		Diagnosis delay time	—

### POSSIBLE CAUSE

Temperature around the ICC sensor becomes extremely low or high.

### FAIL-SAFE

The following systems are canceled:

- Intelligent Cruise Control
- Forward Emergency Braking (FEB)
- Predictive Forward Collision Warning (PFCW)

### DTC CONFIRMATION PROCEDURE

#### 1. PERFORM DTC CONFIRMATION PROCEDURE

##### Ⓜ CONSULT

1. Turn the ignition switch OFF.
2. Wait for 10 minutes or more.
3. Start the engine.
4. Turn the MAIN switch of ICC system ON.
5. Select "Self Diagnostic Result" mode of "LASER/RADAR".
6. Check if the "C1A21" is detected as the current malfunction in "Self Diagnostic Result" mode of "LASER/RADAR".

##### Is "C1A21" detected as the current malfunction?

- YES >> Refer to [CCS-93, "Diagnosis Procedure"](#).
- NO-1 >> To check malfunction symptom before repair: Refer to [GI-41, "Intermittent Incident"](#).
- NO-2 >> Confirmation after repair: Inspection End.

### Diagnosis Procedure

INFOID:0000000011952991

#### 1. CHECK ENGINE COOLING SYSTEM

Check for any malfunctions in engine cooling system.

##### Is engine cooling system normal?

- YES >> Replace the ICC sensor. Refer to [CCS-136, "Removal and Installation"](#).
- NO >> Repair engine cooling system.

CCS

# C1A24 NP RANGE

< DTC/CIRCUIT DIAGNOSIS >

[ICC]

## C1A24 NP RANGE

### DTC Description

INFOID:000000011952992

### DTC DETECTION LOGIC

DTC No.	CONSULT screen terms	DTC detection condition	
C1A24	NP RANGE (NP range)	Diagnosis condition	When ignition switch is ON.
		Signal (terminal)	—
		Threshold	A mismatch between a shift position signal transmitted from TCM via CAN communication and a current gear position signal continues for 60 seconds or more.
		Diagnosis delay time	—

### POSSIBLE CAUSE

- TCM
- Transmission range switch

### FAIL-SAFE

The following systems are canceled:

- Intelligent Cruise Control
- Forward Emergency Braking (FEB)
- Predictive Forward Collision Warning (PFCW)

### DTC CONFIRMATION PROCEDURE

#### 1.CHECK DTC PRIORITY

If DTC "C1A24" is displayed with DTC "U1000", first diagnose the DTC "U1000".

##### Is applicable DTC detected?

- YES >> Perform diagnosis of applicable DTC. Refer to [CCS-111, "DTC Logic"](#).  
NO >> GO TO 2.

#### 2.CHECK DTC(1)

##### ⓐ CONSULT

1. Start the engine.
2. Turn the MAIN switch of ICC system ON.
3. Wait for approximately 5 minutes or more after shifting the selector lever to "P" position.
4. Select "Self Diagnostic Result" mode of "LASER/RADAR".
5. Check if the "C1A24" is detected as the current malfunction in "Self Diagnostic Result" mode of "LASER/RADAR".

##### Is "C1A24" detected as the current malfunction?

- YES >> Refer to [CCS-94, "Diagnosis Procedure"](#).  
NO >> GO TO 3.

#### 3.CHECK DTC (2)

##### ⓐ CONSULT

1. Wait for approximately 5 minutes or more after shifting the selector lever to "N" position.
2. "Self Diagnostic Result" mode of "ICC/ADAS".
3. Check if the "C1A24" is detected as the current malfunction in "Self Diagnostic Result" mode of "ICC/ADAS".

##### Is "C1A24" detected as the current malfunction?

- YES >> Refer to [CCS-94, "Diagnosis Procedure"](#).  
NO-1 >> To check malfunction symptom before repair: Refer to [GI-41, "Intermittent Incident"](#).  
NO-2 >> Confirmation after repair: Inspection End.

### Diagnosis Procedure

INFOID:000000011952993

#### 1.CHECK DTC PRIORITY

# C1A24 NP RANGE

[ICC]

## < DTC/CIRCUIT DIAGNOSIS >

If DTC “C1A24” is displayed with DTC “U1000”, first diagnose the DTC “U1000”.

### Is applicable DTC detected?

- YES >> Perform diagnosis of applicable DTC. Refer to [CCS-111, "DTC Logic"](#).
- NO >> GO TO 2.

## 2.CHECK TCM DATA MONITOR

### Ⓜ CONSULT

Check that “SLCT LVR POSI” operates normally in “Data Monitor” mode of “TRANSMISSION”.

### Is the inspection result normal?

- YES >> GO TO 3.
- NO >> Perform diagnosis for transmission range switch circuit and repair or replace the malfunctioning parts. Refer to [TM-101, "Component Inspection"](#).

## 3.PERFORM TCM SELF DIAGNOSTIC RESULT

### Ⓜ CONSULT

1. “Self Diagnostic Result” mode of “TRANSMISSION”.
2. Check if any DTC is detected in “Self Diagnostic Result” mode of “TRANSMISSION”.

### Is any DTC detected?

- YES >> Perform diagnosis on the detected DTC and repair or replace the malfunctioning parts. Refer to [TM-58, "DTC Index"](#).
- NO >> Replace the ADAS control unit. Refer to [DAS-80, "Removal and Installation"](#).

A  
B  
C  
D  
E  
F  
G  
H  
I  
J  
K  
L  
M  
N  
P

CCS

# C1A26 ECD MODE MALFUNCTION

< DTC/CIRCUIT DIAGNOSIS >

[ICC]

## C1A26 ECD MODE MALFUNCTION

### DTC Description

INFOID:000000011952994

### DTC DETECTION LOGIC

DTC No.	CONSULT screen terms	DTC detection condition	
C1A26	ECD MODE MALF (ECD mode malfunction)	Diagnosis condition	When ignition switch is ON.
		Signal (terminal)	—
		Threshold	If an abnormal condition occurs with ECD system
		Diagnosis delay time	—

#### POSSIBLE CAUSE

- ABS actuator and electric unit (control unit)
- ADAS control unit

#### FAIL-SAFE

The following systems are canceled:

- Intelligent Cruise Control
- Forward Emergency Braking (FEB)
- Predictive Forward Collision Warning

### DTC CONFIRMATION PROCEDURE

#### 1. CHECK DTC PRIORITY

If DTC "C1A26" is displayed with DTC "U1000", "U0415" or "U0121", first diagnose the DTC "U1000", "U0415" or "U0121".

##### Is applicable DTC detected?

- YES >> Perform diagnosis of applicable.
- U1000: Refer to [CCS-111, "DTC Logic"](#).
  - U0415: Refer to [CCS-104, "DTC Description"](#).
  - U0121: Refer to [CCS-104, "DTC Description"](#).
  - C1A0C: Refer to [CCS-117, "DTC Description"](#).
  - C1A50: Refer to [CCS-102, "DTC Description"](#).

NO >> GO TO 2.

#### 2. PERFORM DTC CONFIRMATION PROCEDURE

##### CONSULT

1. Start the engine.
2. Wait for approximately 1 minute after turning the MAIN switch of ICC system ON.
3. Select "Self Diagnostic Result" mode of "LASER/RADAR".
4. Check if the "C1A26" is detected as the current malfunction in "Self Diagnostic Result" mode of "LASER/RADAR".

##### Is "C1A26" detected as the current malfunction?

- YES >> Refer to [CCS-96, "Diagnosis Procedure"](#).
- NO-1 >> To check malfunction symptom before repair: Refer to [GI-41, "Intermittent Incident"](#).
- NO-2 >> Confirmation after repair: Inspection End.

### Diagnosis Procedure

INFOID:000000011952995

#### 1. CHECK DTC PRIORITY

If DTC "C1A26" is displayed with DTC "U1000", "U0415" or "U0121", first diagnose the DTC "U1000", "U0415" or "U0121" or "C1A0C" or "C1A50".

##### Is applicable DTC detected?

- YES >> Perform diagnosis of applicable.
- U1000: Refer to [CCS-111, "DTC Logic"](#).
  - U0415: Refer to [CCS-108, "DTC Description"](#).
  - U0121: Refer to [CCS-104, "DTC Description"](#).



## C1A26 ECD MODE MALFUNCTION

< DTC/CIRCUIT DIAGNOSIS >

[ICC]

- C1A0C: Refer to [CCS-117, "DTC Description"](#).
- C1A50: Refer to [CCS-102, "DTC Description"](#).

NO >> GO TO 2.

### 2.PERFORM SELF DIAGNOSTIC RESULT OF ABS ACTUATOR AND ELECTRIC UNIT (CONTROL UNIT)

#### CONSULT

Check if any DTC is detected in "Self Diagnostic Result" mode of "ABS".

#### Is any DTC detected?

YES >> Perform diagnosis on the detected DTC and repair or replace the malfunctioning parts. Refer to [BRC-227, "DTC Index"](#).

NO >> Replace ICC sensor. Refer to [DAS-80, "Removal and Installation"](#).

A  
B  
C  
D  
E  
F  
G  
H  
I  
J  
K  
L  
M  
N  
P

CCS

# C1A27 ECD POWER SUPPLY CIRCUIT

< DTC/CIRCUIT DIAGNOSIS >

[ICC]

## C1A27 ECD POWER SUPPLY CIRCUIT

### DTC Description

INFOID:000000011952996

### DTC DETECTION LOGIC

DTC No.	CONSULT screen terms	DTC detection condition	
C1A27	ECD PWR SUPPLY CIR (ECD power supply circuit)	Diagnosis condition	When ignition switch is ON.
		Signal (terminal)	—
		Threshold	ECD system power supply voltage is excessively low
		Diagnosis delay time	—

### POSSIBLE CAUSE

- ABS actuator and electric unit (control unit) power supply circuit
- ABS actuator and electric unit (control unit)

### FAIL-SAFE

The following systems are canceled:

- Intelligent Cruise Control
- Forward Emergency Braking (FEB)
- Predictive Forward Collision Warning

### DTC CONFIRMATION PROCEDURE

#### 1. CHECK DTC PRIORITY

##### CONSULT

If DTC "C1A27" is displayed with DTC "U1000", "U0415" or "U0121", first diagnose the DTC "U1000", "U0415" or "U0121".

##### Is applicable DTC detected?

- YES >> Perform diagnosis of applicable.
- U1000: Refer to [CCS-111, "DTC Logic"](#).
  - U0415: Refer to [CCS-108, "DTC Description"](#).
  - U0121: Refer to [CCS-104, "DTC Description"](#).
- NO >> GO TO 2.

#### 2. PERFORM DTC CONFIRMATION PROCEDURE

##### CONSULT

1. Start the engine.
2. Wait for approximately 1 minute after turning the MAIN switch of ICC system ON.
3. Select "Self Diagnostic Result" mode of "LASER/RADAR".
4. Check if the "C1A27" is detected as the current malfunction in "Self Diagnostic Result" mode of "LASER/RADAR".

##### Is "C1A27" detected as the current malfunction?

- YES >> Refer to [CCS-98, "Diagnosis Procedure"](#).
- NO-1 >> To check malfunction symptom before repair: Refer to [GI-41, "Intermittent Incident"](#).
- NO-2 >> Confirmation after repair: Inspection End.

### Diagnosis Procedure

INFOID:000000011952997

#### 1. CHECK DTC PRIORITY

If DTC "C1A27" is displayed with DTC "U1000", "U0415" or "U0121", first diagnose the DTC "U1000", "U0415" or "U0121".

##### Is applicable DTC detected?

- YES >> Perform diagnosis of applicable.
- U1000: Refer to [CCS-111, "DTC Logic"](#).
  - U0415: Refer to [CCS-108, "DTC Description"](#).
  - U0121: Refer to [CCS-104, "DTC Description"](#).

# C1A27 ECD POWER SUPPLY CIRCUIT

[ICC]

< DTC/CIRCUIT DIAGNOSIS >

NO >> GO TO 2.

## 2. CHECK POWER SUPPLY CIRCUIT OF ABS ACTUATOR AND ELECTRIC UNIT (CONTROL UNIT)

Check power supply circuit of ABS actuator and electric unit (control unit). Refer to [BRC-276, "Diagnosis Procedure"](#).

Is the inspection result normal?

YES >> Perform "Self Diagnostic Result" mode of ABS actuator and electric unit (control unit). Refer to [BRC-227, "DTC Index"](#).

NO >> Repair the harnesses or connectors.

A  
B  
C  
D  
E  
F  
G  
H  
I  
J  
K  
L  
M  
N  
P

CCS

# C1A39 STEERING ANGLE SENSOR

< DTC/CIRCUIT DIAGNOSIS >

[ICC]

## C1A39 STEERING ANGLE SENSOR

### DTC Description

INFOID:000000011952998

### DTC DETECTION LOGIC

DTC No.	CONSULT screen terms	DTC detecting condition	
C1A39	STRG SEN CIR (Steering angle sensor circuit)	Diagnosis condition	When ignition switch is ON.
		Signal (terminal)	—
		Threshold	If the steering angle sensor is malfunctioning
		Diagnosis delay time	—

### POSSIBLE CAUSE

Steering angle sensor

### FAIL-SAFE

The following systems are canceled:

- Intelligent Cruise Control
- Forward Emergency Braking (FEB)
- Predictive Forward Collision Warning (PFCW)

### DTC CONFIRMATION PROCEDURE

#### 1. CHECK DTC PRIORITY

If DTC "C1A39" is displayed with DTC "U1000", first diagnose the DTC "U1000".

Is applicable DTC detected?

- YES >> Perform diagnosis of applicable DTC. Refer to [CCS-111, "DTC Logic"](#).  
NO >> GO TO 2.

#### 2. PERFORM DTC CONFIRMATION PROCEDURE

##### Ⓜ CONSULT

1. Start the engine.
2. Turn the MAIN switch of ICC system ON.
3. Select "Self Diagnostic Result" mode of "LASER/RADAR".
4. Check if the "C1A39" is detected as the current malfunction in "Self Diagnostic Result" mode of "LASER/RADAR".

Is "C1A39" detected as the current malfunction?

- YES >> Refer to [CCS-100, "Diagnosis Procedure"](#).  
NO-1 >> To check malfunction symptom before repair: Refer to [GI-41, "Intermittent Incident"](#).  
NO-2 >> Confirmation after repair: Inspection End.

### Diagnosis Procedure

INFOID:000000011952999

#### 1. CHECK DTC PRIORITY

If DTC "C1A39" is displayed with DTC "U1000", first diagnose the DTC "U1000".

Is applicable DTC detected?

- YES >> Perform diagnosis of applicable. Refer to [CCS-111, "DTC Logic"](#).  
NO >> GO TO 2.

#### 2. CHECK ABS ACTUATOR AND ELECTRIC UNIT (CONTROL UNIT) SELF DIAGNOSTIC RESULTS

##### Ⓜ CONSULT

Check if any DTC is detected in "Self Diagnostic Result" mode of "ABS".

Is any DTC detected?

- YES >> Perform diagnosis on the detected DTC and repair or replace the malfunctioning parts. Refer to [BRC-227, "DTC Index"](#).  
NO >> Replace the ICC sensor. Refer to [DAS-80, "Removal and Installation"](#).

# C1B5D FEB OPE COUNT LIMIT

< DTC/CIRCUIT DIAGNOSIS >

[ICC]

## C1B5D FEB OPE COUNT LIMIT

### DTC Description

INFOID:0000000011953000

### DTC DETECTION LOGIC

DTC No.	CONSULT screen terms	DTC detection condition	
C1B5D	FEB OPE COUNT LIMIT (Forward Emergency Braking operation count limit)	Diagnosis condition	When ignition switch is ON.
		Signal (terminal)	—
		Threshold	FEB system operated 3 times within ignition switch ON.
		Diagnosis delay time	—

#### NOTE:

If “C1B5D” is detected, perform the ICC system action test and check that ICC system operates normally.

#### POSSIBLE CAUSE

- FEB system operated 3 times within ignition switch ON.

#### FAIL-SAFE

—

#### DTC CONFIRMATION PROCEDURE

##### 1. PERFORM ICC SYSTEM ACTION TEST

#### CONSULT

Perform the ICC system action test.

Is there any malfunction symptom?

- YES >> Refer to [CCS-101, "Diagnosis Procedure"](#).
- NO >> Inspection End.

#### Diagnosis Procedure

INFOID:0000000011953001

##### 1. CHECK SELF DIAGNOSTIC RESULT

#### CONSULT

1. Turn ignition switch OFF.
2. Turn ignition switch ON.
3. Select “Self Diagnostic Result” mode of “LASER/RADAR”.
4. Check if the “C1B5D” is detected as the current malfunction in “Self Diagnostic Result” mode of “LASER/RADAR”.

Is “C1B5D” detected as a current malfunction?

- YES >> Replace the ICC sensor. Refer to [CCS-136, "Removal and Installation"](#).
- NO >> Perform ICC system action test. Refer to [CCS-66, "Description"](#).

CCS

## C1A50 ADAS CONTROL UNIT

### DTC Description

INFOID:000000011953002

### DTC DETECTION LOGIC

DTC No.	CONSULT screen terms	DTC detection condition	
C1A50	ADAS MALFUNCTION	Diagnosis condition	When ignition switch is ON.
		Signal (terminal)	—
		Threshold	If ADAS control unit is malfunctioning
		Diagnosis delay time	—

**NOTE:**

If DTC “C1A50” is detected along with DTC “U1000” or “C1A0C” first diagnose the DTC “U1000” or “C1A0C”. Refer to [CCS-111, "DTC Logic"](#).

**POSSIBLE CAUSE**

- ADAS control unit

**FAIL-SAFE**

The following systems are canceled:

- Intelligent Cruise Control
- Forward Emergency Braking (FEB)
- Predictive Forward Collision Warning (PFCW)

## 1. PERFORM DTC CONFIRMATION PROCEDURE

**CONSULT**

1. Start the engine.
2. Turn the MAIN switch of ICC system ON.
3. Select “Self Diagnostic Result” mode of “LASER/RADAR”.
4. Check if the “C1A50” is detected as the current malfunction in “Self Diagnostic Result” mode of “LASER/RADAR”.

Is “C1A50” detected as the current malfunction?

- YES >> Refer to [CCS-102, "Diagnosis Procedure"](#).  
 NO >> Refer to [GI-41, "Intermittent Incident"](#).

## Diagnosis Procedure

INFOID:000000011953003

### 1. CHECK ICC SENSOR SELF-DIAGNOSIS RESULTS

If DTC “C1A50” is displayed with “U1000” diagnose the DTC “U1000” first.

Is “U1000” detected?

- YES >> Perform diagnosis of applicable DTC. Refer to [CCS-111, "DTC Logic"](#) or [CCS-117, "DTC Description"](#).  
 NO >> GO TO 2.

### 2. CHECK ADAS CONTROL UNIT SELF-DIAGNOSIS RESULTS

**CONSULT**

Check if any DTC is detected in “Self Diagnostic Result” mode of “ICC/ADAS”.

Is any DTC detected?

- YES >> Perform diagnosis on the detected DTC and repair or replace the malfunctioning parts. Refer to [CCS-46, "DTC Index"](#).  
 NO >> Replace the ICC sensor. Refer to [CCS-136, "Removal and Installation"](#).

# C10B7 YAW RATE SENSOR

< DTC/CIRCUIT DIAGNOSIS >

[ICC]

## C10B7 YAW RATE SENSOR

### DTC Description

INFOID:0000000011953004

### DTC DETECTION LOGIC

DTC No.	CONSULT screen terms	DTC detection condition	
C10B7	YAW RATE SENSOR	Diagnosis condition	When ignition switch is ON.
		Signal (terminal)	—
		Threshold	The yaw rate/side/decel G sensor calibration is incorrect.
		Diagnosis delay time	—

### POSSIBLE CAUSE

- The calibration of yaw rate/side/decel G sensor is not yet performed.
- Interruption in yaw rate/side/decel G sensor calibration

### FAIL-SAFE

The following systems are canceled:

- Intelligent Cruise Control
- Forward Emergency Braking (FEB)
- Predictive Forward Collision Warning (PFCW)

### DTC CONFIRMATION PROCEDURE

#### 1. PERFORM DTC CONFIRMATION PROCEDURE

##### CONSULT

1. Start the engine.
2. Turn the MAIN switch of ICC system ON.
3. Select "Self Diagnostic Result" mode of "LASER/RADAR".
4. Check if the "C10B7" is detected as the current malfunction in "Self Diagnostic Result" mode of "LASER/RADAR".

Is "C10B7" detected as the current malfunction?

- YES >> Refer to [CCS-103, "Diagnosis Procedure"](#).  
NO >> Inspection End.

### Diagnosis Procedure

INFOID:0000000011953005

#### 1. PERFORM CALIBRATION OF THE YAW RATE/SIDE/DECEL G SENSOR

##### CONSULT

1. Perform calibration of the yaw rate/side/decel G sensor. Refer to [BRC-250, "Work Procedure"](#).
2. Erase "Self Diagnostic Result" with CONSULT.
3. Select "Self Diagnostic Result" mode of "LASER/RADAR".
4. Check if the "C10B7" is detected in "Self Diagnostic Result" mode of "LASER/RADAR".

Is "C10B7" detected?

- YES >> Replace the ICC sensor. Refer to [CCS-136, "Removal and Installation"](#).  
NO >> Inspection End.

A  
B  
C  
D  
E  
F  
G  
H  
I  
J  
K  
L  
M  
N  
P

CCS

U0121 VDC CAN 2

DTC Description

INFOID:000000011953006

DTC DETECTION LOGIC

DTC No.	CONSULT screen terms	DTC detection condition	
U0121	VDC CAN CIR2 (VDC CAN circuit 2)	Diagnosis condition	When ignition switch is ON.
		Signal (terminal)	—
		Threshold	If ICC sensor detects an error signal that is received from ABS actuator and electric unit (control unit) via CAN communication
		Diagnosis delay time	—

POSSIBLE CAUSE

ABS actuator and electric unit (control unit)

FAIL-SAFE

The following systems are canceled.

- Intelligent Cruise Control
- Forward Emergency Braking (FEB)
- Predictive Forward Collision Warning (PFCW)

DTC CONFIRMATION PROCEDURE

1.CHECK DTC PRIORITY

If DTC “U0121” is displayed with DTC “U1000”, first diagnose the DTC “U1000”.

Is applicable DTC detected?

- YES >> Perform diagnosis of applicable DTC. Refer to [CCS-111, "DTC Logic"](#).
- NO >> GO TO 2.

2.PERFORM DTC CONFIRMATION PROCEDURE

Ⓜ CONSULT

1. Start the engine.
2. Turn the MAIN switch of ICC system ON.
3. Select “Self Diagnostic Result” mode of “LASER/RADAR”.
4. Check if the “U0121” is detected as the current malfunction in “Self Diagnostic Result” mode of “LASER/RADAR”.

Is “U0121” detected as the current malfunction?

- YES >> Refer to [CCS-104, "Diagnosis Procedure"](#).
- NO-1 >> To check malfunction symptom before repair: Refer to [GI-41, "Intermittent Incident"](#).
- NO-2 >> Confirmation after repair: Inspection End.

Diagnosis Procedure

INFOID:000000011953007

1.CHECK DTC PRIORITY

If DTC “U0121” is displayed with DTC “U1000”, first diagnose the DTC “U1000”.

Is applicable DTC detected?

- YES >> Perform diagnosis of applicable DTC. Refer to [CCS-111, "DTC Description"](#).
- NO >> GO TO 2.

2.CHECK ABS ACTUATOR AND ELECTRIC UNIT (CONTROL UNIT) SELF DIAGNOSTIC RESULT

Ⓜ CONSULT

Check if any DTC is detected in “Self Diagnostic Result” mode of “ABS”.

Is any DTC detected?

- YES >> Perform diagnosis on the detected DTC and repair or replace the malfunctioning parts. Refer to [BRC-234, "DTC Index"](#).



U0121 VDC CAN 2

< DTC/CIRCUIT DIAGNOSIS >

[ICC]

NO >> Replace the ICC sensor. Refer to [DAS-80. "Removal and Installation"](#).

- A
- B
- C
- D
- E
- F
- G
- H
- I
- J
- K
- L
- M
- N
- P

CCS

## U0126 STRG SEN CAN 1

### DTC Description

INFOID:000000011953008

### DTC DETECTION LOGIC

DTC No.	CONSULT screen terms	DTC detection condition	
U0126	STRG SEN CAN CIR1 (Steering sensor CAN circuit 1)	Diagnosis condition	When ignition switch is ON.
		Signal (terminal)	—
		Threshold	If ICC sensor detects an error signal that is received from steering angle sensor via CAN communication
		Diagnosis delay time	—

### POSSIBLE CAUSE

Steering angle sensor

### FAIL-SAFE

The following systems are canceled:

- Intelligent Cruise Control
- Forward Emergency Braking (FEB)
- Predictive Forward Collision Warning (PFCW)

### DTC CONFIRMATION PROCEDURE

#### 1. CHECK DTC PRIORITY

If DTC “U0126” is displayed with DTC “U1000”, first diagnose the DTC “U1000”.

##### Is applicable DTC detected?

- YES >> Perform diagnosis of applicable DTC. Refer to [CCS-111, "DTC Description"](#).  
 NO >> GO TO 2.

#### 2. PERFORM DTC CONFIRMATION PROCEDURE

##### Ⓟ CONSULT

1. Start the engine.
2. Turn the MAIN switch of ICC system ON.
3. Select “Self Diagnostic Result” mode of “LASER/RADAR”.
4. Check if the “U0126” is detected as the current malfunction in “Self Diagnostic Result” mode of “LASER/RADAR”.

##### Is “U0126” detected as the current malfunction?

- YES >> Refer to [CCS-106, "Diagnosis Procedure"](#).  
 NO-1 >> To check malfunction symptom before repair: Refer to [GI-41, "Intermittent Incident"](#).  
 NO-2 >> Confirmation after repair: Inspection End.

### Diagnosis Procedure

INFOID:000000011953009

#### 1. CHECK DTC PRIORITY

If DTC “U0126” is displayed with DTC “U1000”, first diagnose the DTC “U1000”.

##### Is applicable DTC detected?

- YES >> Perform diagnosis of applicable DTC. Refer to [CCS-111, "DTC Description"](#).  
 NO >> GO TO 2.

#### 2. CHECK ABS ACTUATOR AND ELECTRIC UNIT (CONTROL UNIT) SELF DIAGNOSTIC RESULT

##### Ⓟ CONSULT

Check if any DTC is detected in “Self Diagnostic Result” mode of “ABS”.

##### Is any DTC detected?

- YES >> Perform diagnosis on the detected DTC and repair or replace the malfunctioning parts. Refer to [BRC-227, "DTC Index"](#).  
 NO >> Replace the ADAS control unit. Refer to [DAS-80, "Removal and Installation"](#).

# U0401 ECM CAN 1

< DTC/CIRCUIT DIAGNOSIS >

[ICC]

## U0401 ECM CAN 1

### DTC Description

INFOID:0000000011953010

### DTC DETECTION LOGIC

DTC No.	CONSULT screen terms	DTC detection condition	
U0401	ECM CAN CIR1 (ECM CAN circuit 1)	Diagnosis condition	When ignition switch is ON.
		Signal (terminal)	—
		Threshold	If ADAS control unit detects an error signal that is received from ECM via CAN communication
		Diagnosis delay time	—

### POSSIBLE CAUSE

ECM

### FAIL-SAFE

The following systems are canceled:

- Intelligent Cruise Control
- Forward Emergency Braking (FEB)
- Predictive Forward Collision Warning (PFCW)

### DTC CONFIRMATION PROCEDURE

#### 1. CHECK DTC PRIORITY

If DTC “U0401” is displayed with DTC “U1000”, first diagnose the DTC “U1000”.

##### Is applicable DTC detected?

- YES >> Perform diagnosis of applicable DTC. Refer to [CCS-111, "DTC Description"](#).  
 NO >> GO TO 2.

#### 2. PERFORM DTC CONFIRMATION PROCEDURE

##### CONSULT

1. Start the engine.
2. Turn the MAIN switch of ICC system ON.
3. Select “Self Diagnostic Result” mode of “LASER/RADAR”.
4. Check if the “U0401” is detected as the current malfunction in “Self Diagnostic Result” mode of “LASER/RADAR”.

##### Is “U0401” detected as the current malfunction?

- YES >> Refer to [CCS-107, "Diagnosis Procedure"](#).  
 NO-1 >> To check malfunction symptom before repair: Refer to [GI-41, "Intermittent Incident"](#).  
 NO-2 >> Confirmation after repair: Inspection End.

### Diagnosis Procedure

INFOID:0000000011953011

#### 1. CHECK DTC PRIORITY

If DTC “U0401” is displayed with DTC “U1000”, first diagnose the DTC “U1000”.

##### Is applicable DTC detected?

- YES >> Perform diagnosis of applicable DTC. Refer to [CCS-111, "DTC Description"](#).  
 NO >> GO TO 2.

#### 2. CHECK ECM SELF DIAGNOSTIC RESULT

##### CONSULT

Check if any DTC is detected in “Self Diagnostic Result” mode of “ENGINE”.

##### Is any DTC detected?

- YES >> Perform diagnosis on the detected DTC and repair or replace the malfunctioning parts. Refer to [EC-107, "DTC Index"](#).  
 NO >> Replace the ICC sensor. Refer to [CCS-136, "Removal and Installation"](#).

A  
B  
C  
D  
E  
F  
G  
H  
I  
J  
K  
L  
M  
N  
P



**U0415 VDC CAN 1**

**DTC Description**

INFOID:0000000011953012

**DTC DETECTION LOGIC**

DTC No.	CONSULT screen terms	DTC detection condition	
U0415	VDC CAN CIR1 (VDC CAN circuit1)	Diagnosis condition	When ignition switch is ON.
		Signal (terminal)	—
		Threshold	If ICC sensor detects an error signal that is received from ABS actuator and electric unit (control unit) via CAN communication
		Diagnosis delay time	—

**POSSIBLE CAUSE**

ABS actuator and electric unit (control unit)

**FAIL-SAFE**

The following systems are canceled:

- Intelligent Cruise Control
- Forward Emergency Braking (FEB)
- Predictive Forward Collision Warning (PFCW)

**DTC CONFIRMATION PROCEDURE**

**1.CHECK DTC PRIORITY**

If DTC “U0415” is displayed with DTC “U1000”, first diagnose the DTC “U1000”.

Is applicable DTC detected?

- YES >> Perform diagnosis of applicable DTC. Refer to [CCS-111, "DTC Description"](#).  
 NO >> GO TO 2.

**2.PERFORM DTC CONFIRMATION PROCEDURE**

Ⓜ CONSULT

1. Start the engine.
2. Turn the MAIN switch of ICC system ON.
3. Select “Self Diagnostic Result” mode of “LASER/RADAR”.
4. Check if the “U0415” is detected as the current malfunction in “Self Diagnostic Result” mode of “LASER/RADAR”.

Is “U0415” detected as the current malfunction?

- YES >> Refer to [CCS-108, "Diagnosis Procedure"](#).  
 NO-1 >> To check malfunction symptom before repair: Refer to [GI-41, "Intermittent Incident"](#).  
 NO-2 >> Confirmation after repair: Inspection End.

**Diagnosis Procedure**

INFOID:0000000011953013

**1.CHECK DTC PRIORITY**

If DTC “U0415” is displayed with DTC “U1000”, first diagnose the DTC “U1000”.

Is applicable DTC detected?

- YES >> Perform diagnosis of applicable DTC. Refer to [CCS-111, "DTC Description"](#).  
 NO >> GO TO 2.

**2.CHECK ABS ACTUATOR AND ELECTRIC UNIT (CONTROL UNIT) SELF DIAGNOSTIC RESULT**

Ⓜ CONSULT

Check if any DTC is detected in “Self Diagnostic Result” mode of “ABS”.

Is any DTC detected?

- YES >> Perform diagnosis on the detected DTC and repair or replace the malfunctioning parts. Refer to [BRC-227, "DTC Index"](#).

# U0415 VDC CAN 1

< DTC/CIRCUIT DIAGNOSIS >

[ICC]

NO >> Replace the ICC sensor. Refer to [CCS-136. "Removal and Installation"](#).

A

B

C

D

E

F

G

H

I

J

K

L

M

N

CCS

P

U0428 STRG SEN CAN 2

DTC Description

INFOID:000000011953014

DTC DETECTION LOGIC

DTC No.	CONSULT screen terms	DTC detection condition	
U0428	STRG SEN CAN CIR2 (Steering sensor CAN circuit2)	Diagnosis condition	When ignition switch is ON.
		Signal (terminal)	—
		Threshold	If ICC sensor detects an error signal that is received from steering angle sensor via CAN communication
		Diagnosis delay time	—

POSSIBLE CAUSE

Steering angle sensor

FAIL-SAFE

The following systems are canceled:

- Intelligent Cruise Control
- Forward Emergency Braking (FEB)
- Predictive Forward Collision Warning (PFCW)

DTC CONFIRMATION PROCEDURE

1.CHECK DTC PRIORITY

If DTC “U0428” is displayed with DTC “U1000”, first diagnose the DTC “U1000”.

Is applicable DTC detected?

- YES >> Perform diagnosis of applicable DTC. Refer to [CCS-111, "DTC Description"](#).
- NO >> GO TO 2.

2.PERFORM DTC CONFIRMATION PROCEDURE

Ⓟ CONSULT

1. Start the engine.
2. Turn the MAIN switch of ICC system ON.
3. Select “Self Diagnostic Result” mode of “LASER/RADAR”.
4. Check if the “U0428” is detected as the current malfunction in “Self Diagnostic Result” mode of “LASER/RADAR”.

Is “U0428” detected as the current malfunction?

- YES >> Refer to [CCS-110, "Diagnosis Procedure"](#).
- NO-1 >> To check malfunction symptom before repair: Refer to [GI-41, "Intermittent Incident"](#).
- NO-2 >> Confirmation after repair: Inspection End.

Diagnosis Procedure

INFOID:000000011953015

1.CHECK DTC PRIORITY

If DTC “U0428” is displayed with DTC “U1000”, first diagnose the DTC “U1000”.

Is applicable DTC detected?

- YES >> Perform diagnosis of applicable DTC. Refer to [CCS-111, "DTC Description"](#).
- NO >> GO TO 2.

2.CHECK ABS ACTUATOR AND ELECTRIC UNIT (CONTROL UNIT) SELF DIAGNOSTIC RESULT

Ⓟ CONSULT

Check if any DTC is detected in “Self Diagnostic Result” mode of “ABS”.

Is any DTC detected?

- YES >> Perform diagnosis on the detected DTC and repair or replace the malfunctioning parts. Refer to [BRC-227, "DTC Index"](#).
- NO >> Replace the ADAS control unit. Refer to [DAS-80, "Removal and Installation"](#).

# U1000 CAN COMM CIRCUIT

< DTC/CIRCUIT DIAGNOSIS >

[ICC]

## U1000 CAN COMM CIRCUIT

### DTC Description

INFOID:0000000011953016

### ITS COMMUNICATION

- ITS communication is a multiplex communication system. This enables the system to transmit and receive large quantities of data at high speeds by connecting control units with two communication lines.
- ITS communication lines adopt twisted-pair line style (two lines twisted) for noise immunity.

### DTC Logic

INFOID:0000000011953017

### DTC DETECTION LOGIC

DTC No.	CONSULT screen terms	DTC detection condition	
U1000	CAN COMM CIRCUIT (CAN communication circuit)	Diagnosis condition	When ignition switch is ON.
		Signal (terminal)	—
		Threshold	If ICC sensor is not transmitting or receiving ITS communication signal
		Diagnosis delay time	2 seconds or more

### POSSIBLE CAUSE

ITS communication system

### FAIL-SAFE

The following systems are canceled:

- Intelligent Cruise Control
- Forward Emergency Braking (FEB)
- Predictive Forward Collision Warning (PFCW)

### DTC CONFIRMATION PROCEDURE

#### 1. PERFORM DTC CONFIRMATION PROCEDURE

##### Ⓜ CONSULT

1. Start the engine.
2. Turn the MAIN switch of ICC system ON.
3. Select "Self Diagnostic Result" mode of "LASER/RADAR".
4. Check if the "U1000" is detected as the current malfunction in "Self Diagnostic Result" mode of "LASER/RADAR".

Is "U1000" detected as the current malfunction?

- YES >> Refer to [CCS-111, "Diagnosis Procedure"](#).
- NO-1 >> To check malfunction symptom before repair: Refer to [GI-41, "Intermittent Incident"](#).
- NO-2 >> Confirmation after repair: Inspection End.

### Diagnosis Procedure

INFOID:0000000011953018

#### 1. PERFORM THE SELF DIAGNOSTIC RESULT

##### Ⓜ CONSULT

1. Turn the ignition switch ON.
2. Turn the MAIN switch of ICC system ON, and then wait for 2 seconds or more.
3. Select "Self Diagnostic Result" mode of "LASER/RADAR".
4. Check if the "U1000" is detected as the current malfunction in "Self Diagnostic Result" mode of "LASER/RADAR".

Is "U1000" detected as the current malfunction?

- YES >> Refer to [LAN-17, "Trouble Diagnosis Flow Chart"](#).
- NO >> Inspection End.

# U1010 CONTROL UNIT (CAN)

< DTC/CIRCUIT DIAGNOSIS >

[ICC]

## U1010 CONTROL UNIT (CAN)

### DTC Description

INFOID:000000011953019

CAN controller controls the communication of ITS communication signal and the error detection.

### DTC Logic

INFOID:000000011953020

### DTC DETECTION LOGIC

DTC No.	CONSULT screen terms	DTC detection condition	
U1010	CONTROL UNIT (CAN) [Control unit (CAN)]	Diagnosis condition	When ignition switch is ON.
		Signal (terminal)	—
		Threshold	If ICC sensor detects malfunction by CAN controller initial diagnosis
		Diagnosis delay time	—

### POSSIBLE CAUSE

ICC sensor

### FAIL-SAFE

The following systems are canceled:

- Intelligent Cruise Control
- Forward Emergency Braking (FEB)
- Predictive Forward Collision Warning (PFCW)

### DTC CONFIRMATION PROCEDURE

#### 1. PERFORM DTC CONFIRMATION PROCEDURE

##### CONSULT

1. Start the engine.
2. Turn the MAIN switch of ICC system ON.
3. Select "Self Diagnostic Result" mode of "LASER/RADAR".
4. Check if the "U1010" is detected as the current malfunction in "Self Diagnostic Result" mode of "LASER/RADAR".

##### Is "U1010" detected as the current malfunction?

- YES >> Refer to [CCS-112, "Diagnosis Procedure"](#).
- NO-1 >> To check malfunction symptom before repair: Refer to [GI-41, "Intermittent Incident"](#).
- NO-2 >> Confirmation after repair: Inspection End.

### Diagnosis Procedure

INFOID:000000011953021

#### 1. PERFORM DTC CONFIRMATION PROCEDURE

##### CONSULT

1. Turn the MAIN switch of ICC system ON.
2. Select "Self Diagnostic Result" mode of "LASER/RADAR".
3. Check if the "U1010" is detected as the current malfunction in "Self Diagnostic Result" mode of "LASER/RADAR".

##### Is "U1010" detected as the current malfunction?

- YES >> Replace the ICC sensor. Refer to [CCS-136, "Removal and Installation"](#).
- NO >> Inspection End.



# POWER SUPPLY AND GROUND CIRCUIT

< DTC/CIRCUIT DIAGNOSIS >

[ICC]

## POWER SUPPLY AND GROUND CIRCUIT ICC SENSOR

### ICC SENSOR : Diagnosis Procedure

INFOID:0000000011953022

Regarding Wiring Diagram information, refer to [CCS-49, "Wiring Diagram"](#).

#### 1. CHECK ICC SENSOR POWER SUPPLY CIRCUIT

Check voltage between ICC sensor harness connector and ground.

(+)		(-)		Condition	Standard voltage	Voltage (Approx.)
ICC sensor						
Connector	Terminal					
E245	8	1		OFF	0 - 0.1 V	0 V
				ON	9.5 - 16 V	Battery voltage

Is the inspection result normal?

YES >> GO TO 2.

NO >> Repair the ICC sensor power supply circuit.

#### 2. CHECK ICC SENSOR GROUND CIRCUIT

1. Turn the ignition switch OFF.
2. Disconnect the ICC sensor connector.
3. Check for continuity between ICC sensor harness connector and ground.

ICC sensor		Ground	Continuity
Connector	Terminal		
E245	1		Yes

Is the inspection result normal?

YES >> Inspection End.

NO >> Repair the ICC sensor ground circuit.

A  
B  
C  
D  
E  
F  
G  
H  
I  
J  
K  
L  
M  
N  
P

CCS

C1A07 CVT

DTC Description

INFOID:000000011953023

DTC DETECTION LOGIC

DTC No.	CONSULT screen terms	DTC detection condition	
C1A07	CVT MSG CIRCUIT	Diagnosis condition	When ignition switch is ON.
		Signal (terminal)	—
		Threshold	If ICC sensor detects an error signal that is received from TCM via CAN communication.
		Diagnosis delay time	—

POSSIBLE CAUSE

TCM

FAIL-SAFE

The following systems are canceled:

- Intelligent Cruise Control
- Forward Emergency Braking (FEB)
- Predictive Forward Collision Warning (PFCW)

DTC CONFIRMATION PROCEDURE

1.PERFORM DTC CONFIRMATION PROCEDURE

Ⓟ CONSULT

1. Start the engine.
2. Turn the MAIN switch of ICC system ON.
3. Select “Self Diagnostic Result” mode of “LASER/RADAR”.
4. Check if the “C1A07” is detected as the current malfunction in “Self Diagnostic Result” mode of “LASER/RADAR”.

Is “U1A07” detected as the current malfunction?

- YES >> Refer to [CCS-114, "Diagnosis Procedure"](#).  
 NO >> Refer to [GI-41, "Intermittent Incident"](#).

Diagnosis Procedure

INFOID:000000011953024

1.CHECK ICC SENSOR SELF-DIAGNOSIS RESULT

Check if “U1000” is also detected with “C1A07” in “Self Diagnostic Result” mode of “LASER/RADAR”.

Is “U1000” detected?

- YES >> Perform the CAN communication system inspection. Repair or replace the malfunctioning parts. Refer to [CCS-111, "DTC Description"](#).  
 NO >> GO TO 2.

2.CHECK TCM SELF DIAGNOSTIC RESULTS

Ⓟ CONSULT

Check if any DTC is detected in “Self Diagnostic Result” mode of “TRANSMISSION”.

Is any DTC detected?

- YES >> Perform diagnosis on the detected DTC and repair or replace the malfunctioning parts. Refer to [TM-58, "DTC Index"](#).  
 NO >> Replace the ICC sensor. Refer to [CCS-136, "Removal and Installation"](#).

# U153A CVT MESSAGE COUNTER FAILURE

< DTC/CIRCUIT DIAGNOSIS >

[ICC]

## U153A CVT MESSAGE COUNTER FAILURE

### DTC Description

INFOID:0000000011953025

### DTC DETECTION LOGIC

DTC No.	Trouble diagnosis name	DTC detection condition	
U153A	CVT MSG COUNTER	Diagnosis condition	When ignition switch is ON.
		Signal (terminal)	—
		Threshold	If ICC sensor detects an error signal that is received from TCM via CAN communication
		Diagnosis delay time	—

### POSSIBLE CAUSE

TCM

### FAIL-SAFE

The following systems are canceled:

- Intelligent Cruise Control
- Forward Emergency Braking (FEB)
- Predictive Forward Collision Warning (PFCW)

### DTC CONFIRMATION PROCEDURE

#### 1. PERFORM DTC CONFIRMATION PROCEDURE

##### CONSULT

1. Start the engine.
2. Turn the MAIN switch of ICC system ON.
3. Select "Self Diagnostic Result" mode of "LASER/RADAR".
4. Check if the "U153A" is detected as the current malfunction in "Self Diagnostic Result" mode of "LASER/RADAR".

Is "U153A" detected as the current malfunction?

- YES >> Refer to [CCS-115, "Diagnosis Procedure"](#).  
NO >> Refer to [GI-41, "Intermittent Incident"](#).

### Diagnosis Procedure

INFOID:0000000011953026

#### 1. CHECK ICC SENSOR SELF DIAGNOSTIC RESULTS

Check if "U1000" is also detected with "U153A" in "Self Diagnostic Result" mode of "LASER/RADAR".

Is "U1000" detected?

- YES >> Perform the CAN communication system inspection. Repair or replace the malfunctioning parts.  
Refer to [CCS-111, "DTC Logic"](#).  
NO >> GO TO 2.

#### 2. CHECK TCM SELF DIAGNOSTIC RESULT

##### CONSULT

Check if any DTC is detected in "Self Diagnostic Result" mode of "TRANSMISSION".

Is any DTC detected?

- YES >> Perform diagnosis on the detected DTC and repair or replace the malfunctioning parts. Refer to [TM-58, "DTC Index"](#).  
NO >> Replace the ICC sensor. Refer to [CCS-136, "Removal and Installation"](#).

# U153B CVT CHECK SUM FAILURE

< DTC/CIRCUIT DIAGNOSIS >

[ICC]

## U153B CVT CHECK SUM FAILURE

### DTC Description

INFOID:0000000011953027

### DTC DETECTION LOGIC

DTC No.	CONSULT screen terms	DTC detection condition	
U153B	CVT MSG COUNTER	Diagnosis condition	When ignition switch is ON.
		Signal (terminal)	—
		Threshold	If ICC sensor detects an error signal that is received from TCM via CAN communication
		Diagnosis delay time	—

### POSSIBLE CAUSE

TCM

### FAIL-SAFE

The following systems are canceled:

- Intelligent Cruise Control
- Forward Emergency Braking (FEB)
- Predictive Forward Collision Warning (PFCW)

### DTC CONFIRMATION PROCEDURE

#### 1.PERFORM DTC CONFIRMATION PROCEDURE

##### Ⓟ CONSULT

1. Start the engine.
2. Turn the MAIN switch of ICC system ON.
3. Select "Self Diagnostic Result" mode of "LASER/RADAR".
4. Check if the "U153B" is detected as the current malfunction in "Self Diagnostic Result" mode of "LASER/RADAR".

Is "U153B" detected as the current malfunction?

YES >> Refer to [CCS-116, "Diagnosis Procedure"](#).

NO >> Refer to [GI-41, "Intermittent Incident"](#).

### Diagnosis Procedure

INFOID:0000000011953028

#### 1.CHECK ICC SENSOR SELF DIAGNOSTIC RESULT

Check if "U1000" is detected other than "U153B" in "Self Diagnostic Result" mode of "LASER/RADAR".

Is "U1000" detected?

YES >> Perform the CAN communication system inspection. Repair or replace the malfunctioning parts.  
Refer to [CCS-111, "DTC Logic"](#).

NO >> GO TO 2.

#### 2.CHECK TCM SELF DIAGNOSTIC RESULT

##### Ⓟ CONSULT

Check if any DTC is detected in "Self Diagnostic Result" mode of "TRANSMISSION".

Is any DTC detected?

YES >> Perform diagnosis on the detected DTC and repair or replace the malfunctioning parts. Refer to [CCS-111, "DTC Logic"](#).

NO >> Replace the ICC sensor. Refer to [CCS-136, "Removal and Installation"](#).

# C1A0C ADAS MESSAGE COUNTER FAILURE

< DTC/CIRCUIT DIAGNOSIS >

[ICC]

## C1A0C ADAS MESSAGE COUNTER FAILURE

### DTC Description

INFOID:0000000011953029

### DTC DETECTION LOGIC

DTC No.	CONSULT terms	DTC detection condition	
C1A0C	ADAS MSG COUNTER	Diagnosis condition	When ignition switch is ON.
		Signal (terminal)	—
		Threshold	ICC sensor internal malfunction
		Diagnosis delay time	—

### POSSIBLE CAUSE

ICC Sensor

### FAIL-SAFE

The following systems are canceled:

- Intelligent Cruise Control
- Forward Emergency Braking (FEB)
- Predictive Forward Collision Warning (PFCW)

### DTC CONFIRMATION PROCEDURE

#### 1. PERFORM DTC CONFIRMATION PROCEDURE

##### Ⓜ CONSULT

1. Start the engine.
2. Select "Self Diagnostic Result" mode of "LASER/RADAR".
3. Check if the "C1A0C" is detected as the current malfunction in "Self Diagnostic Result" mode of "LASER/RADAR".

Is "C1A0C" detected as the current malfunction?

- YES >> Refer to [CCS-117, "Diagnosis Procedure"](#).  
NO >> Inspection End.

### Diagnosis Procedure

INFOID:0000000011953030

#### 1. CHECK ICC SENSOR SELF DIAGNOSTIC RESULT

Check if "U1000" is also detected with "C1A0C" in "Self Diagnostic Result" mode of "LASER/RADAR".

Is "U1000" detected?

- YES >> Perform the CAN communication system inspection. Repair or replace the malfunctioning parts.  
Refer to [CCS-111, "DTC Logic"](#).  
NO >> GO TO 2.

#### 2. CHECK ADAS CONTROL UNIT SELF DIAGNOSTIC RESULT

##### Ⓜ CONSULT

Check if any DTC is detected in "Self Diagnostic Result" mode of "ICC/ADAS".

Is any DTC detected?

- YES >> Perform diagnosis on the detected DTC and repair or replace the malfunctioning parts. Refer to [DAS-25, "DTC Index"](#).  
NO >> Replace the ICC sensor. Refer to [CCS-136, "Removal and Installation"](#).

A  
B  
C  
D  
E  
F  
G  
H  
I  
J  
K  
L  
M  
N  
P

CCS

# C1A0D MRR CAN FAILURE

< DTC/CIRCUIT DIAGNOSIS >

[ICC]

## C1A0D MRR CAN FAILURE

### DTC Description

INFOID:000000011953031

### DTC DETECTION LOGIC

DTC No.	Consult screen terms	DTC detection condition	
C1A0D	MRR CAN FAIL	Diagnosis condition	When ignition switch is ON.
		Signal (terminal)	—
		Threshold	ICC sensor internal malfunction
		Diagnosis delay time	—

### POSSIBLE CAUSE

ICC Sensor

### FAIL-SAFE

The following systems are canceled:

- Intelligent Cruise Control
- Forward Emergency Braking (FEB)
- Predictive Forward Collision Warning (PFCW)

### DTC CONFIRMATION PROCEDURE

#### 1. PERFORM DTC CONFIRMATION PROCEDURE

##### Ⓟ CONSULT

1. Start the engine.
2. Turn the MAIN switch of ICC system ON.
3. Select "Self Diagnostic Result" mode of "LASER/RADAR".
4. Check if the "C1A0D" is detected as the current malfunction in "Self Diagnostic Result" mode of "LASER/RADAR".

Is "C1A0D" detected as the current malfunction?

YES >> Refer to [CCS-118, "Diagnosis Procedure"](#).

NO >> Refer to [GI-41, "Intermittent Incident"](#).

### Diagnosis Procedure

INFOID:000000011953032

#### 1. CHECK ICC SENSOR SELF DIAGNOSTIC RESULT

Check if "U1000" is also detected with "C1A0D" in "Self Diagnostic Result" mode of "LASER/RADAR".

Is "U1000" detected?

YES >> Perform the CAN communication system inspection. Repair or replace the malfunctioning parts.  
Refer to [CCS-111, "DTC Logic"](#).

NO >> GO TO 2.

#### 2. CHECK ADAS CONTROL UNIT SELF DIAGNOSTIC RESULT

##### Ⓟ CONSULT

Check if any DTC is detected in "Self Diagnostic Result" mode of "ICC/ADAS".

Is any DTC detected?

YES >> Perform diagnosis on the detected DTC and repair or replace the malfunctioning parts. Refer to [DAS-25, "DTC Index"](#).

NO >> Replace the ICC sensor. Refer to [CCS-136, "Removal and Installation"](#).

# INTELLIGENT CRUISE CONTROL SYSTEM SYMPTOMS

< SYMPTOM DIAGNOSIS >

[ICC]

## SYMPTOM DIAGNOSIS

### INTELLIGENT CRUISE CONTROL SYSTEM SYMPTOMS

#### Symptom Table

INFOID:0000000011953033

Symptoms		Reference page
Operation	MAIN switch does not turn ON	<a href="#">CCS-120. "Description"</a>
	MAIN switch does not turn OFF	
	ICC system cannot be set (MAIN switch turns ON/OFF)	<a href="#">CCS-122. "Description"</a>
	CANCEL switch does not function	
	Resume does not function	
	Set speed does not increase	<a href="#">CCS-124. "Description"</a>
	Set distance to a vehicle ahead cannot be changed	
	ICC is not canceled when the CVT selector lever is in "N" position	<a href="#">CCS-125. "Description"</a>
Display/Chime	ICC system display does not appear	<a href="#">CCS-15. "INTELLIGENT CRUISE CONTROL : System Description"</a>
	Chime does not sound	<a href="#">CCS-126. "Description"</a>
Control	Driving force is hunting	<a href="#">CCS-128. "Description"</a>
Function to detect a vehicle ahead	System frequently cannot detect a vehicle ahead	<a href="#">CCS-129. "Description"</a>
	Distance to detect a vehicle ahead is short	
	System misidentifies a vehicle even though there is no vehicle ahead	<ul style="list-style-type: none"> <li>Adjust radar alignment. Refer to <a href="#">CCS-59. "Description"</a>.</li> <li>Perform ICC system action test. Refer to <a href="#">CCS-66. "Description"</a>.</li> </ul>
	System misidentifies a vehicle in the next lane	
	System does not detect a vehicle at all	<a href="#">CCS-131. "Description"</a>

A  
B  
C  
D  
E  
F  
G  
H  
I  
J  
K  
L  
M  
N  
P

CCS

# MAIN SWITCH DOES NOT TURN ON, MAIN SWITCH DOES NOT TURN OFF

< SYMPTOM DIAGNOSIS >

[ICC]

## MAIN SWITCH DOES NOT TURN ON, MAIN SWITCH DOES NOT TURN OFF

### Description

INFOID:000000011953034

MAIN switch does not turn ON

- ICC system display does not appear even when MAIN switch is pressed.

MAIN switch does not turn OFF

- When ICC system display is ON, display does not turn OFF even if MAIN switch is pressed.

#### NOTE:

When ICC system warning lamp illuminates, perform the self-diagnosis of ICC system, and then repair or replace the malfunctioning parts.

### Diagnosis Procedure

INFOID:000000011953035

#### 1.MAIN SWITCH INSPECTION

##### Ⓟ CONSULT

1. Start the engine.
2. Check that "MAIN SW" and "CRUISE LAMP" operate normally in "Data Monitor" mode of "ICC/ADAS".

Is the inspection result normal?

- YES >> GO TO 2.
- NO >> GO TO 4.

#### 2.CHECK COMBINATION METER

##### Ⓟ CONSULT

Check that "CRUISE IND" operates normally in "Data Monitor" mode of "METER/M&A".

Is the inspection result normal?

- YES >> GO TO 3.
- NO >> GO TO 4.

#### 3.PERFORM SELF DIAGNOSTIC RESULT OF COMBINATION METER

##### Ⓟ CONSULT

1. Select "Self Diagnostic Result" mode of "METER/M&A".
2. Check if DTC is detected. Refer to [MWI-29, "DTC Index"](#).

Is any DTC detected?

- YES >> Repair or replace malfunctioning parts.
- NO >> GO TO 4.

#### 4.PERFORM SELF DIAGNOSTIC RESULT OF ICC SYSTEM

##### Ⓟ CONSULT

1. Select "Self Diagnostic Result" mode of "ICC/ADAS".
2. Check if DTC "U1000" is detected in .

Is "U1000" detected?

- YES >> GO TO 5.
- NO >> GO TO 6.

#### 5.CAN COMMUNICATION INSPECTION

Check the CAN communication and repair or replace malfunctioning parts. Refer to [LAN-8, "System Description"](#).

>> Inspection End.

#### 6.CHECK ICC STEERING SWITCH

Check the ICC steering switch. Refer to [CCS-138, "Exploded View"](#).



# MAIN SWITCH DOES NOT TURN ON, MAIN SWITCH DOES NOT TURN OFF

< SYMPTOM DIAGNOSIS >

[ICC]

>> Inspection End.

A

B

C

D

E

F

G

H

I

J

K

L

M

N

CCS

P

# ICC SYSTEM CANNOT BE SET (MAIN SWITCH TURNS ON/OFF)

< SYMPTOM DIAGNOSIS >

[ICC]

## ICC SYSTEM CANNOT BE SET (MAIN SWITCH TURNS ON/OFF)

### Description

INFOID:000000011953036

The MAIN switch can be turned ON/OFF, but the ICC system cannot be set even if the SET/COAST switch is pressed.

#### NOTE:

The system cannot be set in the following cases:

- When the vehicle ahead is not detected below the speed of 32 km/h (20 MPH).
- When the selector lever is not in the “D” position or manual mode.
- When the brake pedal is depressed.
- When the VDC is turned OFF.
- When ABS or VDC (including the TCS) operates.
- When a wheel slips.
- When ABS warning lamp is ON.

### Diagnosis Procedure

INFOID:000000011953037

#### 1. CHECK CAUSE OF AUTOMATIC CANCELLATION

##### CONSULT

Check if the cancellation cause in the “CAUSE OF AUTO-CANCEL” in “Work support” mode of “LASER/RADAR”.

##### Is it displayed?

Not displayed >> GO TO 2.

“OPE SW VOLT CIRC” >> Refer to [CCS-79, "DTC Description"](#).

“VHCL SPD UNMATCH” >> Refer to [CCS-72, "DTC Description"](#).

“IGN LOW VOLT” >> Refer to [CCS-98, "DTC Description"](#).

“ECM CIRCUIT” >> Refer to [CCS-85, "DTC Description"](#).

“CAN COMM ERROR” >> Refer to [CCS-111, "DTC Logic"](#).

“ICC SENSOR CAN COMM ERR” >> Refer to [CCS-113, "ICC SENSOR : Diagnosis Procedure"](#).

“ABS/TCS/VDC CIRC” >> Refer to [CCS-96, "DTC Description"](#).

“ECD CIRCUIT” >> Refer to [CCS-96, "DTC Description"](#).

#### 2. PERFORM THE SELF DIAGNOSTIC RESULT

##### CONSULT

1. Select “Self Diagnostic Result” mode of “LASER/RADAR”.
2. Check if any DTC is detected in “Self Diagnostic Result” mode of “ICC/ADAS” or “LASER/RADAR”. Refer to [CCS-46, "DTC Index"](#) (ICC/ADAS) or [CCS-46, "DTC Index"](#) (LASER/RADAR).

##### Is any DTC detected?

YES >> GO TO 3.

NO >> GO TO 4.

#### 3. REPAIR OR REPLACE MALFUNCTIONING PARTS

Repair or replace malfunctioning parts identified by the self-diagnosis result.

>> GO TO 6.

#### 4. CHECK EACH SWITCH AND VEHICLE SPEED SIGNAL

##### CONSULT

1. Start the engine.
2. Check that the following items operate normally in “Data Monitor” mode of “LASER/RADAR”:
  - “VHCL SPEED SE”
  - “D RANGE SW”
  - “SET/COAST SW”
  - “BRAKE SW”
  - “PKB SW”

##### Is there a malfunctioning item?

All items are normal >> GO TO 5.

# ICC SYSTEM CANNOT BE SET (MAIN SWITCH TURNS ON/OFF)

[ICC]

< SYMPTOM DIAGNOSIS >

“VHCL SPEED SE”>> Refer to [CCS-72, "DTC Description"](#).

“D RANGE SW”>> Refer to [CCS-87, "DTC Logic"](#).

“SET/COAST SW”>> Refer to [CCS-79, "DTC Description"](#).

“BRAKE SW”>> Refer to [CCS-75, "DTC Description"](#).

“PKB SW”>> Refer to [CCS-74, "DTC Description"](#).

## 5. REPLACE ICC SENSOR

Replace the ICC sensor. Refer to [CCS-136, "Removal and Installation"](#).

>> GO TO 6.

## 6. CHECK ICC SYSTEM

### Ⓜ CONSULT

1. Erase the “Self Diagnostic Result”, and then select “Self Diagnostic Result” mode again after performing the action test. (Refer to [CCS-66, "Description"](#) for action test.)
2. Check that the ICC system is normal.

>> Inspection End.

A  
B  
C  
D  
E  
F  
G  
H  
I  
J  
K  
L  
M  
N  
P

CCS

# ICC STEERING SWITCH (OTHER THAN MAIN SWITCH) DOES NOT FUNCTION

< SYMPTOM DIAGNOSIS >

[ICC]

## ICC STEERING SWITCH (OTHER THAN MAIN SWITCH) DOES NOT FUNCTION

### Description

INFOID:000000011953038

MAIN switch can be turned ON/OFF, but the operation of RESUME/+ switch, CANCEL switch, and DISTANCE switch cannot be performed during ICC system operation.

#### NOTE:

Resume is not accepted when the following condition is met:

- When the MAIN switch is turned OFF once.

### Diagnosis Procedure

INFOID:000000011953039

#### 1. CHECK EACH SWITCH

##### CONSULT

1. Start the engine.
2. Check that each switch operates normally on "Data Monitor" mode of "LASER/RADAR":
  - "RESUME/ACC SW"
  - "CANCEL SW"
  - "DISTANCE SW"

Is the inspection result normal?

- YES >> GO TO 5.  
NO >> GO TO 2.

#### 2. PERFORM THE SELF DIAGNOSTIC RESULT

##### CONSULT

1. Select "Self Diagnostic Result" mode of "LASER/RADAR".
2. Check if DTC "U1000" is detected.

Is "U1000" detected?

- YES >> GO TO 3.  
NO >> GO TO 4.

#### 3. CAN COMMUNICATION INSPECTION

Check the CAN communication and repair or replace malfunctioning parts. Refer to [CCS-111, "DTC Logic"](#).

>> Inspection End.

#### 4. CHECK ICC STEERING SWITCH

Check the ICC steering switch. Refer to [CCS-138, "Exploded View"](#).

>> GO TO 6.

#### 5. REPLACE ICC SENSOR

Replace the ICC sensor. Refer to [CCS-136, "Removal and Installation"](#).

>> GO TO 6.

#### 6. CHECK ICC SYSTEM

##### CONSULT

1. Erase the "Self Diagnostic Result", and then select "Self Diagnostic Result" mode again after performing the action test. (Refer to [CCS-66, "Description"](#) for action test.)
2. Check that the ICC system is normal.

>> Inspection End.

# ICC SYSTEM DOES NOT CANCEL WHEN CVT SELECTOR LEVER SETS ON "N" [ICC]

< SYMPTOM DIAGNOSIS >

## ICC SYSTEM DOES NOT CANCEL WHEN CVT SELECTOR LEVER SETS ON "N"

### Description

INFOID:0000000011953040

The ICC system is not canceled even when the CVT selector lever is shifted to the "N" position while the ICC system is active.

### Diagnosis Procedure

INFOID:0000000011953041

#### 1. CHECK D RANGE SWITCH

##### CONSULT

Check if "D RANGE SW" operates normally in "Data Monitor" mode of "LASER/RADAR".

Is the inspection result normal?

- YES >> GO TO 6.
- NO >> GO TO 2.

#### 2. PERFORM DIAGNOSTIC RESULT

##### CONSULT

1. Select "Self Diagnostic Result" mode of "LASER/RADAR".
2. Check if DTC "U1000" is detected in .

Is "U1000" detected?

- YES >> GO TO 3.
- NO >> GO TO 4.

#### 3. CAN COMMUNICATION INSPECTION

Check the CAN communication and repair or replace malfunctioning parts. Refer to [CCS-111, "DTC Logic"](#).

>> Inspection End.

#### 4. CHECK POSITION SWITCH

##### CONSULT

Check if "RANGE" operates normally in "Data Monitor" mode of "TRANSMISSION".

Is the inspection result normal?

- YES >> GO TO 6.
- NO >> GO TO 5.

#### 5. PERFORM TCM SELF DIAGNOSTIC RESULT

##### CONSULT

1. Select "Self Diagnostic Result" mode of "TRANSMISSION".
2. Repair or replace malfunctioning parts. Refer to [TM-58, "DTC Index"](#).

>> GO TO 7.

#### 6. REPLACE ICC SENSOR

Replace the ICC sensor. Refer to [CCS-136, "Removal and Installation"](#).

>> GO TO 7.

#### 7. CHECK ICC SYSTEM

##### CONSULT

1. Erase the "Self Diagnostic Result", and then select "Self Diagnostic Result" again after performing the action test. (Refer to [CCS-66, "Description"](#) for action test.)
2. Check that the ICC system is normal.

>> Inspection End.

A  
B  
C  
D  
E  
F  
G  
H  
I  
J  
K  
L  
M  
N  
P

# CHIME DOES NOT SOUND

< SYMPTOM DIAGNOSIS >

[ICC]

## CHIME DOES NOT SOUND

### Description

INFOID:000000011953042

Symptom check: In the following conditions, the warning chime may not sound even if the vehicle distance is short:

- When the vehicles are traveling at the same speed and the distance between vehicles is not changing.
- When the vehicle ahead is traveling faster and the distance between vehicles is increasing.
- When the accelerator pedal is depressed, overriding the system.
- When own vehicle approaches vehicles that are parked or moving slowly.
- The warning chime does not sound when the system does not detect any vehicle ahead. (Diagnose the conditions under which the system is detecting the vehicle ahead and when the system is malfunctioning. If there is any malfunction in detecting the vehicle ahead, check the system. Refer to [CCS-129, "Description"](#).)

### Diagnosis Procedure

INFOID:000000011953043

#### 1.PERFORM ACTIVE TEST

##### Ⓟ CONSULT

Check if the warning chime sounds on the active test item "ICC BUZZER" of "LASER/RADAR".

Does the warning chime sound?

- YES >> GO TO 2.
- NO >> GO TO 3.

#### 2.CHECK THE MALFUNCTION SYMPTOM DURING WARNING CHIME OPERATION

Understand the vehicle ahead detecting condition when the malfunction occurred. If the warning chime should have sounded, replace the ICC sensor. Refer to [DAS-80, "Removal and Installation"](#).

>> GO TO 8.

#### 3.PERFORM ACTIVE TEST

##### Ⓟ CONSULT

Check if the warning chime sounds on the active test item "METER BUZZER" of "ICC/ADAS".

Does the warning chime sound?

- YES >> GO TO 9.
- NO >> GO TO 5.

#### 4.CHECK ICC WARNING CHIME CIRCUIT

Check the meter buzzer circuit. Refer to [WCS-27, "Component Function Check"](#).

Is the inspection result normal?

- YES >> GO TO 8.
- NO >> GO TO 7.

#### 5.PERFORM THE SELF DIAGNOSTIC RESULT

##### Ⓟ CONSULT

1. Select "Self Diagnostic Result" mode of "ICC/ADAS".
2. Check if DTC "U1000" is detected in "Self Diagnostic Result" mode of "ICC/ADAS".

Is "U1000" detected?

- YES >> GO TO 6.
- NO >> GO TO 4.

#### 6.CAN COMMUNICATION SYSTEM INSPECTION

Check the CAN communication system and repair or replace malfunctioning parts. Refer to [CCS-111, "DTC Logic"](#).

>> Inspection End.

#### 7.REPAIR OR REPLACE MALFUNCTIONING PARTS

# CHIME DOES NOT SOUND

< SYMPTOM DIAGNOSIS >

[ICC]

Repair or replace malfunctioning parts.

A

>> GO TO 10.

## 8. REPLACE ADAS CONTROL UNIT

B

Replace the ADAS control unit. Refer to [DAS-80, "Removal and Installation"](#).

>> GO TO 8.

C

## 9. PERFORM ICC SENSOR ALIGNMENT

### CONSULT

D

1. Perform ICC sensor alignment. Refer to [CCS-59, "Description"](#).
2. Perform action test. Refer to [CCS-66, "Description"](#).
3. Check that the vehicle ahead detection performance improves.

E

>> GO TO 10.

## 10. CHECK ICC SYSTEM

F

### CONSULT

1. Erase the "Self Diagnostic Result", and then select "Self Diagnostic Result" mode again after performing the action test. (Refer to [CCS-66, "Description"](#) for action test.)
2. Check that the ICC system is normal.

G

>> Inspection End.

H

I

J

K

L

M

N

CCS

P

## DRIVING FORCE IS HUNTING

### Description

INFOID:000000011953044

The vehicle causes hunting when the ICC system is active.

### Diagnosis Procedure

INFOID:000000011953045

#### 1. PERFORM SELF DIAGNOSTIC RESULT OF ECM

##### Ⓟ CONSULT

1. Select "Self Diagnostic Result".
2. Check if DTC is detected in "Self Diagnostic Result" mode of "ENGINE". Refer to [EC-107, "DTC Index"](#).

##### Is any DTC detected?

- YES >> GO TO 3.  
NO >> GO TO 2.

#### 2. CHECK ICC SENSOR

1. Check the vehicle driving conditions. Refer to [CCS-129, "Description"](#).
2. Check the ICC sensor for contamination, foreign materials, or cracks. Refer to [CCS-129, "Diagnosis Procedure"](#).

>> Inspection End.

#### 3. REPAIR OR REPLACE MALFUNCTIONING PARTS

Repair or replace malfunctioning parts identified by the self-diagnosis result.

>> GO TO 4.

#### 4. CHECK ICC SYSTEM

##### Ⓟ CONSULT

1. Erase the "Self Diagnostic Result", and then perform "Self Diagnostic Result" mode again after performing the action test. (Refer to [CCS-66, "Description"](#) for action test.)
2. Check that the ICC system is normal.

>> Inspection End.



# FREQUENTLY CANNOT DETECT THE VEHICLE AHEAD / DETECTION ZONE IS SHORT

< SYMPTOM DIAGNOSIS >

[ICC]

## FREQUENTLY CANNOT DETECT THE VEHICLE AHEAD / DETECTION ZONE IS SHORT

### Description

INFOID:0000000011953046

The detection function may become unstable in the following cases.

- When radar reflections from the vehicle ahead are interrupted.
- When driving on a road with extremely sharp corners.
- When the sensor cannot detect a vehicle ahead while the vehicle ahead passes a hill or valley.

### Diagnosis Procedure

INFOID:0000000011953047

#### 1.VISUAL CHECK (1)

Check the contamination and foreign matter on the ICC sensor area.

Is foreign matter adhered?

YES >> GO TO 3.

NO >> GO TO 2.

#### 2.VISUAL CHECK (2)

Check ICC sensor for contamination and foreign matter.

Is foreign matter adhered?

YES >> GO TO 3.

NO >> GO TO 4.

#### 3.WIPE OUT DIRT AND FOREIGN MATERIALS

Wipe out the contamination and foreign matter in the area around the ICC sensor.

>> GO TO 8.

#### 4.VISUAL CHECK (3)

Check ICC sensor for cracks and scratches.

Are there any cracks or scratches?

YES >> GO TO 6.

NO >> GO TO 5.

#### 5.ADJUST RADAR ALIGNMENT

1. Adjust the radar alignment. Refer to [CCS-59. "Description"](#).
2. Perform ICC system action test. Refer to [CCS-66. "Description"](#).
3. Check that the vehicle ahead detection performance improves.

Does it improve?

YES >> Inspection End.

NO >> GO TO 6.

#### 6.REPLACE ICC SENSOR

1. Replace the ICC sensor. Refer to [CCS-136. "Removal and Installation"](#).
2. Adjust the radar alignment. Refer to [CCS-59. "Description"](#).
3. Perform ICC system action test. Refer to [CCS-66. "Description"](#).
4. Check that the vehicle ahead detection performance improves.

Does it improve?

YES >> Inspection End.

NO >> GO TO 7.

#### 7.CHECK ICC SYSTEM

##### CONSULT

1. Erase the "Self Diagnostic Result", and then select "Self Diagnostic Result" mode again after performing the action test. (Refer to [CCS-66. "Description"](#) for action test.)
2. Check that the ICC system is normal.

A  
B  
C  
D  
E  
F  
G  
H  
I  
J  
K  
L  
M  
N

P

**FREQUENTLY CANNOT DETECT THE VEHICLE AHEAD / DETECTION ZONE IS SHORT**

< SYMPTOM DIAGNOSIS >

[ICC]

---

>> Inspection End.

# THE SYSTEM DOES NOT DETECT THE VEHICLE AHEAD AT ALL

< SYMPTOM DIAGNOSIS >

[ICC]

## THE SYSTEM DOES NOT DETECT THE VEHICLE AHEAD AT ALL

### Description

INFOID:0000000011953048

When ICC system is active, the ICC system does not perform any control even though there is a vehicle ahead.

### Diagnosis Procedure

INFOID:0000000011953049

#### 1. CHECK ICC SYSTEM DISPLAY ON INFORMATION DISPLAY

1. Start the self-diagnosis mode of combination meter. Refer to [MWI-18, "On Board Diagnosis Function"](#).
2. Check that the information display turns ON normally.

Is the inspection result normal?

- YES >> GO TO 2.  
NO >> Replace the combination meter.

#### 2. VISUAL CHECK (1)

Check the contamination and foreign matter on the ICC sensor area of the front bumper.

Is foreign matter adhered?

- YES >> GO TO 4.  
NO >> GO TO 3.

#### 3. VISUAL CHECK (2)

Check ICC sensor for contamination and foreign matter.

Is foreign matter adhered?

- YES >> GO TO 4.  
NO >> GO TO 5.

#### 4. WIPE OUT DIRT AND FOREIGN MATTER

Wipe out the contamination and foreign matter in the area around the ICC sensor.

>> GO TO 10.

#### 5. VISUAL CHECK (3)

Check ICC sensor for cracks and/or scratches.

Are there cracks or scratches?

- YES >> GO TO 7.  
NO >> GO TO 6.

#### 6. RADAR ALIGNMENT ADJUSTMENT

Ⓜ CONSULT

1. Adjust the radar alignment. Refer to [CCS-59, "Description"](#).
2. Perform ICC system action test. Refer to [CCS-66, "Description"](#).
3. Check that the vehicle ahead detection performance improves.

Does it improve?

- YES >> Inspection End.  
NO >> GO TO 7.

#### 7. CHECK INFORMATION DISPLAY

Ⓜ CONSULT

1. Select "Self Diagnostic Result" mode of "ICC SENSOR". Refer to [CCS-31, "CONSULT Function \(LASER/RADAR\)"](#).
2. Check that the segment of information is displayed normally.

Is the inspection result normal?

- YES >> GO TO 8.  
NO >> Refer to [CCS-46, "DTC Index"](#)

# THE SYSTEM DOES NOT DETECT THE VEHICLE AHEAD AT ALL

< SYMPTOM DIAGNOSIS >

[ICC]

---

## 8. REPLACE ICC SENSOR

---

1. Replace the ICC sensor. Refer to [CCS-136, "Removal and Installation"](#).
2. Adjust the radar alignment. Refer to [CCS-59, "Description"](#).
3. Perform ICC system action test. Refer to [CCS-66, "Description"](#).
4. Check that the vehicle ahead detection performance improves.

### Does it improve?

YES >> Inspection End.

NO >> GO TO 9.

---

## 9. REPLACE ADAS CONTROL UNIT

---

Replace ADAS control unit. Refer to [DAS-80, "Removal and Installation"](#).

>> GO TO 10.

---

## 10. CHECK ICC SYSTEM

---

### CONSULT

1. Erase the "Self Diagnostic Result", and then select "Self Diagnostic Result" mode again after performing the action test. (Refer to [CCS-66, "Description"](#) for action test.)
2. Check that the ICC system is normal.

>> Inspection End.

# NORMAL OPERATING CONDITION

< SYMPTOM DIAGNOSIS >

[ICC]

## NORMAL OPERATING CONDITION

### Description

INFOID:000000011953050

#### PRECAUTIONS FOR INTELLIGENT CRUISE CONTROL SYSTEM

- ICC system is only an aid to assist the driver and is not a collision warning or avoidance system. It is the driver's responsibility to stay alert, drive safely and be in control of the vehicle at all times.
- The system is primarily intended for use on straight, dry, open roads with light traffic. It is not advisable to use the system in city traffic or congested areas.
- This system will not adapt automatically to road conditions. This system should be used in evenly flowing traffic. Never use the system on roads with sharp curves or on icy roads, in heavy rain or in fog.
- The ICC sensor will not detect the following objects:
  - Stationary and slow-moving vehicles.
  - Pedestrians or objects in the roadway.
  - Oncoming vehicles in the same lane.
  - Motorcycles traveling offset in the travel lane.
- As there is a performance limit to the distance control function, never rely solely on the ICC system. This system does not correct careless, inattentive or absent-minded driving or overcome poor visibility in rain, fog, or other bad weather. Decelerate the vehicle speed by depressing the brake pedal, depending on the distance to the vehicle ahead and the surrounding circumstances in order to maintain a safe distance between vehicles.
- If the vehicle ahead comes to a stop, the vehicle decelerates to a standstill within the limitations of the system. The system will cancel once it judges that the vehicle has come to a standstill and sound a warning chime. To prevent the vehicle from moving, the driver must depress the brake pedal.
- The system may not detect the vehicle in front of the driver in certain road or weather conditions. To avoid accidents, never use the ICC system under the following conditions:
  - On roads where the traffic is heavy or there are sharp curves.
  - On slippery road surfaces such as on ice or snow, etc.
  - During bad weather (rain, fog, snow, etc.).
  - When rain, snow or dirt adheres to the ICC sensor.
  - On steep downhill roads (the vehicle may go beyond the set vehicle speed and frequent braking may result in overheating the brakes).
  - On repeated uphill and downhill roads.
  - When traffic conditions make it difficult to keep a proper distance between vehicles because of frequent acceleration or deceleration.
  - Never use the ICC system if own vehicle is towing a trailer. The system may not detect a vehicle ahead.
- In some road or traffic conditions, a vehicle or object can unexpectedly come into the sensor detection zone and cause automatic braking. The driver may need to control the distance from other vehicles using the accelerator pedal. Always stay alert and avoid using the ICC system when it is not recommended in this section.
- The ICC system uses a sensor located behind the front bumper of the vehicle to detect vehicles traveling ahead. The sensor generally detects the signals returned from the vehicle ahead. Therefore, if the sensor cannot detect the reflection from the vehicle ahead, the ICC system may not maintain the selected distance.
- The following are some conditions in which the sensor cannot detect the signals:
  - When the snow or road spray from traveling vehicles reduces the sensor's visibility.
  - When excessively heavy baggage is loaded in the rear seat or the luggage room of own vehicle.
- The ICC system is designed to automatically check the sensor's operation within the limitation of the system. When the front bumper area of the ICC sensor is covered with dirt or is obstructed, the system will automatically cancel. If the front bumper area of the ICC sensor is covered with ice, a transparent or translucent vinyl bag, etc., the ICC system may not detect it. In these instances, the ICC system may not cancel and may not be able to maintain the selected following distance from the vehicle ahead. Be sure to check and clean the front bumper area of the ICC sensor regularly.
- The ICC system does not control vehicle speed or warn the driver when own vehicle approaches stationary and slow moving vehicles. The driver must pay attention to vehicle operation to maintain proper distance from vehicles ahead when approaching toll gates or traffic congestion.

A  
B  
C  
D  
E  
F  
G  
H  
I  
J  
K  
L  
M  
N  
P

CCS

## NORMAL OPERATING CONDITION

[ICC]

### < SYMPTOM DIAGNOSIS >

- The detection zone of the ICC sensor is limited. A vehicle ahead must be in the detection zone for the vehicle-to-vehicle distance detection mode to maintain the selected distance from the vehicle ahead. A vehicle ahead may move outside of the detection zone due to its position within the same lane of travel. Motorcycles may not be detected in the same lane ahead if they are traveling offset from the center line of the lane. A vehicle that is entering the lane ahead may not be detected until the vehicle has completely moved into the lane. If this occurs, the ICC system may warn the driver by blinking the system indicator and sounding the chime. The driver may have to manually control the proper distance from vehicle traveling ahead.

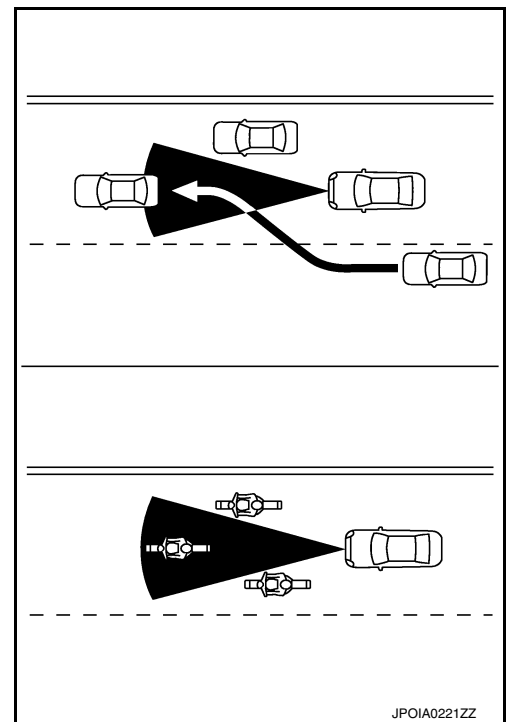

- When driving on some roads, such as winding, hilly, curved narrow roads or roads which are under construction, the ICC sensor may detect vehicles in a different lane or may temporarily not detect a vehicle traveling ahead. This may cause the ICC system to decelerate or accelerate the vehicle. The detection of vehicles may also be affected by vehicle operation (steering maneuver or traveling position in the lane, etc.) or vehicle condition. If this occurs, the ICC system may warn the driver by blinking the system indicator and sounding the chime unexpectedly. The driver will have to manually control the proper distance away from the vehicle traveling ahead.

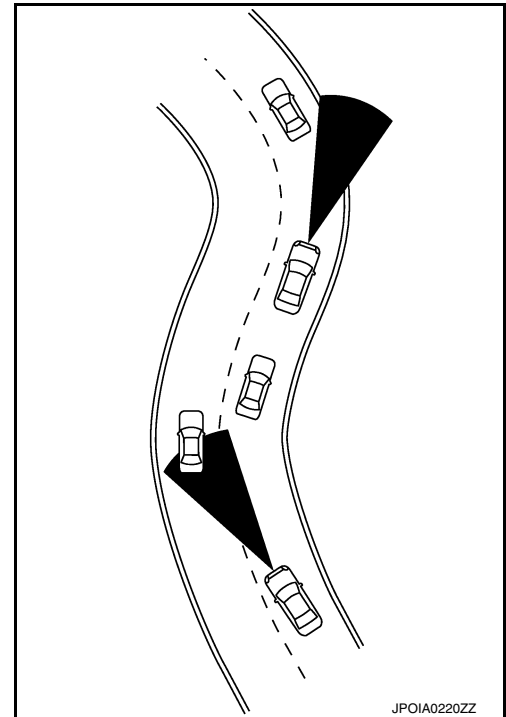

- When driving on the freeway at a set speed and approaching a slower traveling vehicle ahead, the ICC will adjust the speed to maintain the distance, selected by the driver, from the vehicle ahead. If the vehicle ahead changes lanes or exits the freeway, the ICC system will accelerate and maintain the speed up to the set speed. Pay attention to the driving operation to maintain control of the vehicle as it accelerates to the set speed. The vehicle may not maintain the set speed on winding or hilly roads. If this occurs, the driver will have to manually control the vehicle speed.

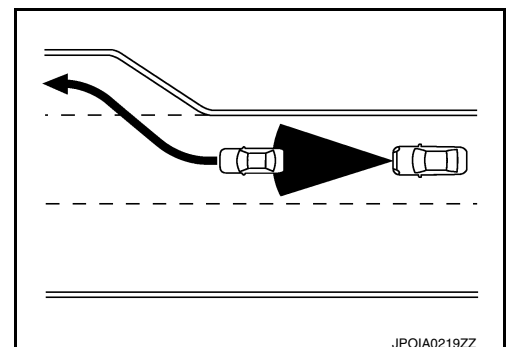

## NORMAL OPERATING CONDITION

< SYMPTOM DIAGNOSIS >

[ICC]

- Normally when controlling the distance to a vehicle ahead, this system automatically accelerates or decelerates own vehicle according to the speed of the vehicle ahead. Depress the accelerator to properly accelerate own vehicle when acceleration is required for a lane change. Depress the brake pedal when deceleration is required to maintain a safe distance to the vehicle ahead due to its sudden braking or if a vehicle cuts in. Always stay alert when using the ICC system.
- The sensor sensitivity can be affected by vehicle operation (steering maneuver or driving position in the lane) or traffic or vehicle condition (for example, if a vehicle is being driven with some damage).

A

B

C

D

E

F

G

H

I

J

K

L

M

N

CCS

P

# ICC SENSOR

< REMOVAL AND INSTALLATION >

[ICC]

## REMOVAL AND INSTALLATION

### ICC SENSOR

#### Exploded View

INFOID:000000011953051

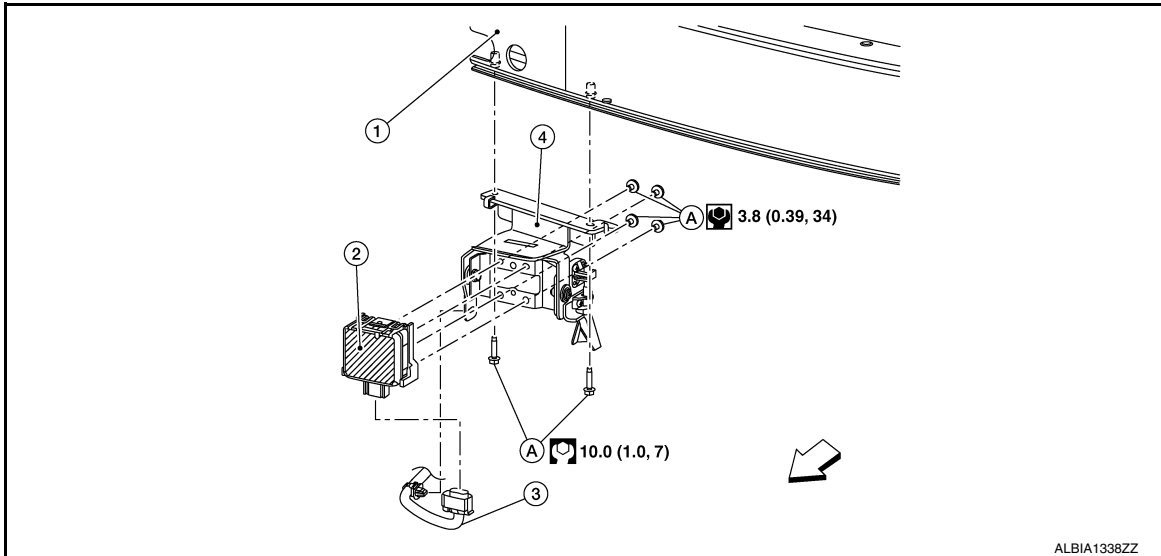

- |                               |                          |                                 |
|-------------------------------|--------------------------|---------------------------------|
| 1. Front bumper reinforcement | 2. ICC sensor            | 3. ICC sensor harness connector |
| 4. ICC sensor bracket         | A. Refer to INSTALLATION | ⇐ Front                         |

### Removal and Installation

INFOID:000000011953052

#### REMOVAL

1. Remove front bumper fascia. Refer to [EXT-17. "Removal and Installation"](#).
2. Disconnect harness connector from ICC sensor.
3. Remove ICC sensor bracket bolts.
4. Remove bolts and detach ICC sensor from ICC sensor bracket.

#### INSTALLATION

Install ICC sensor to ICC sensor bracket.

- Install ICC sensor bolts loosely and then tighten in sequence as shown.

**ICC sensor bolts : 3.8 N·m (0.39 kg-m, 34 in-lb)**

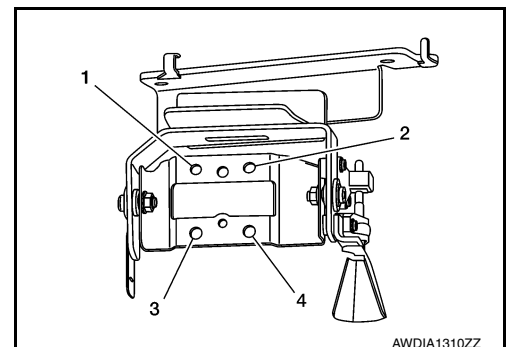

Install ICC sensor bracket to front bumper reinforcement.



## ICC SENSOR

### < REMOVAL AND INSTALLATION >

[ICC]

- Install ICC sensor bracket bolts loosely and then tighten in sequence as shown.

**ICC sensor bracket bolts : 10.0 N·m (1.0 kg-m, 7 ft-lb)**

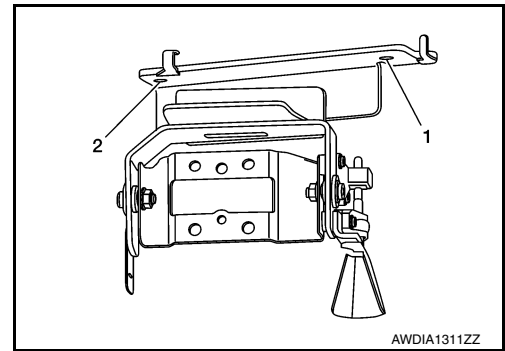

Installation of remaining components is in the reverse order of removal.

#### **CAUTION:**

- **Always perform ICC sensor alignment and check the operation after removal, installation or replacement of ICC sensor. Refer to [CCS-56, "Work Procedure"](#).**
- **Do not touch ICC sensor face.**
- **Do not drop or shock ICC sensor.**
- **Make sure ICC sensor harness is installed without any twists.**

A  
B  
C  
D  
E  
F  
G  
H  
I  
J  
K  
L  
M  
N  
P

CCS

# ICC STEERING SWITCH

< REMOVAL AND INSTALLATION >

[ICC]

## ICC STEERING SWITCH

Exploded View

INFOID:000000011953053

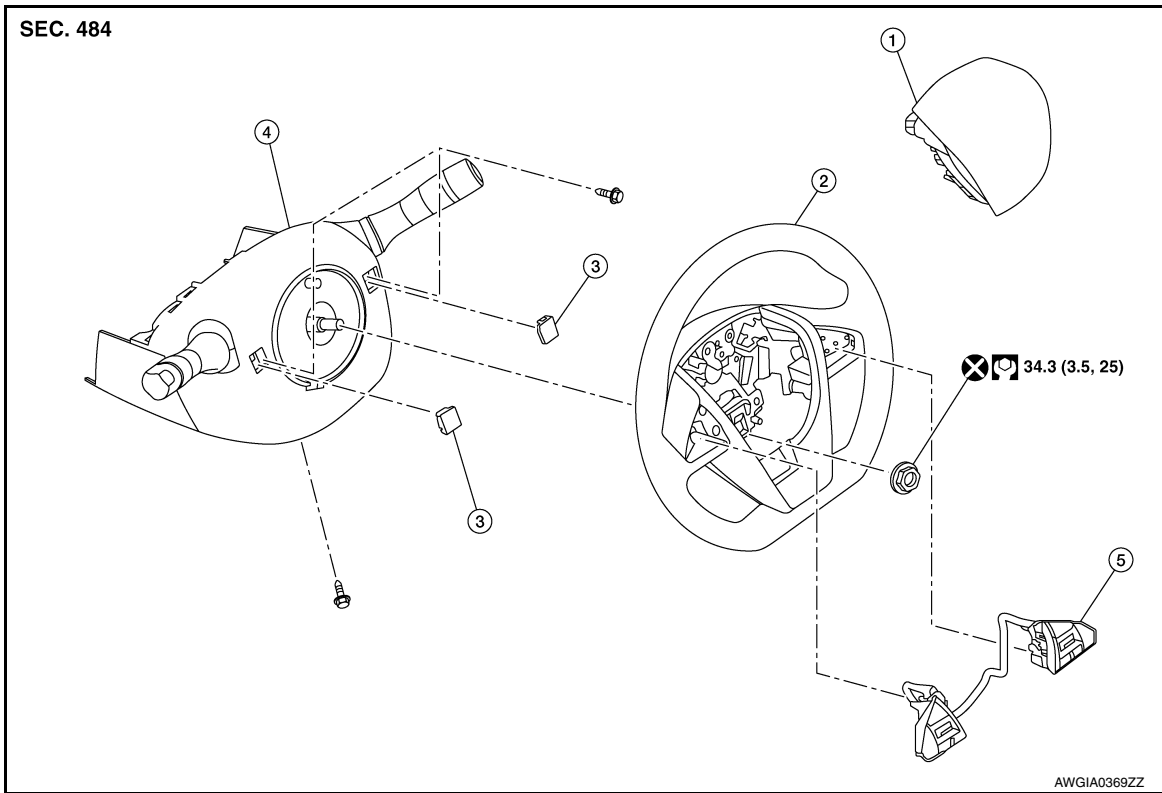

- |                          |                            |          |
|--------------------------|----------------------------|----------|
| 1. Air bag module        | 2. Steering wheel          | 3. Cover |
| 4. Steering column cover | 5. Steering wheel switches |          |

## Removal and Installation

INFOID:000000011953054

### REMOVAL

#### NOTE:

The ICC steering and audio switches are serviced as an assembly.

1. Remove steering wheel. Refer to [ST-30, "Removal and Installation"](#).
2. Remove screws (A) and pawls then remove steering wheel rear finisher (1) from steering wheel (2).

 :Pawls

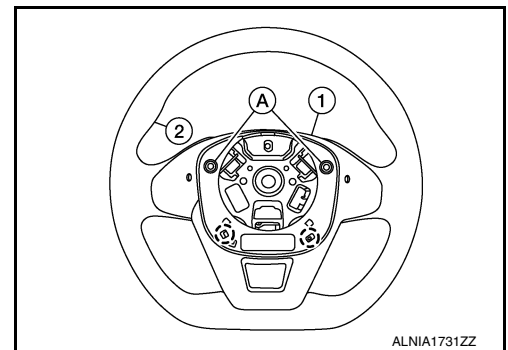

# ICC STEERING SWITCH

[ICC]

## < REMOVAL AND INSTALLATION >

3. Remove screws (A) and pawls then remove steering wheel front finisher (2) from steering wheel (1).

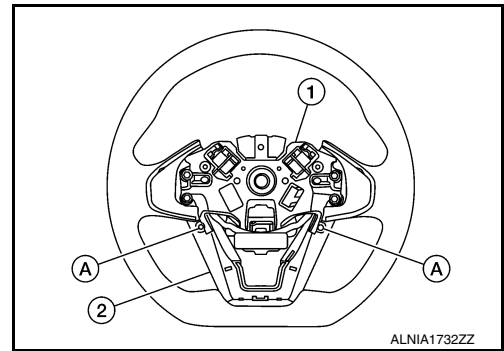

4. Remove screws (A) and remove steering switches from steering wheel (1).

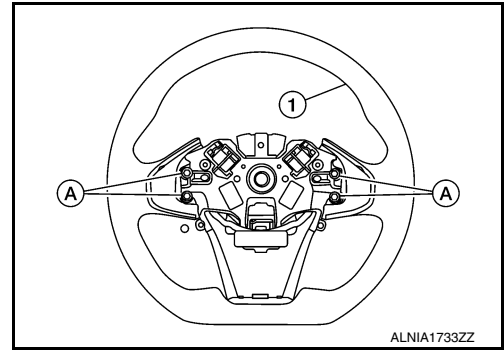

## INSTALLATION

Installation is in the reverse order of removal.

### **CAUTION:**

Always perform ICC system action test to check that the ICC system operates normally after replacing the ICC sensor or repairing any ICC system malfunction. Refer to [CCS-66, "Work Procedure"](#).

A  
B  
C  
D  
E  
F  
G  
H  
I  
J  
K  
L  
M  
N  
P

CCS

## PRECAUTION

### PRECAUTIONS

#### Precaution for Supplemental Restraint System (SRS) "AIR BAG" and "SEAT BELT PRE-TENSIONER"

INFOID:000000011953055

The Supplemental Restraint System such as "AIR BAG" and "SEAT BELT PRE-TENSIONER", used along with a front seat belt, helps to reduce the risk or severity of injury to the driver and front passenger for certain types of collision. Information necessary to service the system safely is included in the SR and SB section of this Service Manual.

**WARNING:**

- To avoid rendering the SRS inoperative, which could increase the risk of personal injury or death in the event of a collision which would result in air bag inflation, it is recommended that all maintenance and repair be performed by an authorized NISSAN/INFINITI dealer.
- Improper repair, including incorrect removal and installation of the SRS, can lead to personal injury caused by unintentional activation of the system. For removal of Spiral Cable and Air Bag Module, see the SR section.
- Do not use electrical test equipment on any circuit related to the SRS unless instructed to in this Service Manual. SRS wiring harnesses can be identified by yellow and/or orange harnesses or harness connectors.

#### PRECAUTIONS WHEN USING POWER TOOLS (AIR OR ELECTRIC) AND HAMMERS

**WARNING:**

- When working near the Air Bag Diagnosis Sensor Unit or other Air Bag System sensors with the Ignition ON or engine running, DO NOT use air or electric power tools or strike near the sensor(s) with a hammer. Heavy vibration could activate the sensor(s) and deploy the air bag(s), possibly causing serious injury.
- When using air or electric power tools or hammers, always switch the Ignition OFF, disconnect the battery or batteries, and wait at least three minutes before performing any service.

# AUTOMATIC SPEED CONTROL DEVICE (ASCD)

< SYSTEM DESCRIPTION >

[ASCD]

## SYSTEM DESCRIPTION

### AUTOMATIC SPEED CONTROL DEVICE (ASCD)

#### Information

INFOID:0000000011953056

Automatic Speed Control Device (ASCD) system is controlled by ECM.  
Regarding the information for ASCD system, refer to the following:

- VQ35DE: [EC-21. "ASCD Steering Switch"](#)

A  
B  
C  
D  
E  
F  
G  
H  
I  
J  
K  
L  
M  
N  
P

